

STATE DEPARTMENT OF GEOLOGY & MINERAL INDUSTRIES
Head Office: 702 Woodlark Bldg., Portland, Oregon

State Governing Board

W. H. Strayer, Chairman Baker
Niel R. Allen Grants Pass
S. H. Williston Portland

Earl K. Nixon Director
F. W. Libbey Mining Engineer
John Eliot Allen Geologist
H. C. Harrison Chief Chemist

State Assay Laboratories

714 E. H Street, Grants Pass

2102 Court Street, Baker
Norman S. Wagner Field Geologist

DIAMONDS

Introduction:

Diamonds are almost unique in that, aside from their unique quality of hardness, they are valued for personal adornment with almost superstitious regard, and at the same time possess qualities which make them essential to industry. As evidence of essentiality, Germany is reported to be using gem stones now for industrial purposes since her outside sources of industrial diamonds were cut off. It is something of a paradox, or more precisely a commentary on human nature, that gem diamonds have a far higher money value than the infinitely more useful but unbeautiful industrial diamonds. A similar quirk in human estimates of value places the monetary worth of a motion picture star far beyond that of a doctor of medicine.

The diamond is the most universally valued of gems. Especially large and perfect stones have a price governed only by what people of wealth are willing to pay. In general, production and marketing are strictly controlled, the money value of cut gem diamonds remaining remarkably constant. The fluctuations in unit commercial values over the years have been small compared to other commodities; the general trend of price has been and is upward. For this reason diamonds have been employed in many countries as "investments." In other words, a person could have more confidence in the value of diamonds than in the money he possessed. Gold, like the diamond, is desired for "investment" or as a safer possession than money, but for the past several years gold as bullion or as coins may not be bought or sold in most countries without government permission. On the other hand a gem diamond may be marketed with ease almost anywhere. Moreover the diamond represents a very concentrated money value and therefore a great wealth may be hoarded and secreted in a very small space.

Because of its hardness there is no satisfactory substitute for the diamond in certain industrial processes and activities. A warring nation is greatly handicapped if supplies are cut off, and since the allies control all diamond-producing centers of consequence Germany has suffered for lack of the industrial varieties.

History:

Of all the well known gem minerals, use of the diamond for adornment is probably the youngest, dating from the fifth or sixth centuries B.C. The other well known precious gems were discovered and cherished at a much earlier period in history. In ancient times diamonds came almost exclusively from India and Borneo. In the 18th century, diamonds were identified in Brazil and, until they were discovered in South Africa, Brazil was the source of nearly all the world's new diamonds.

In 1867 a diamond was found near Hopetown in Cape Colony. This started the great diamond industry in South Africa. At first, placers yielded all the stones, and then the

great kimberlite pipes were found and Kimberley became the center of world production. These discoveries had far-reaching political as well as economic consequences. Cecil Rhodes' control of the mines, his political leadership, the part played by John Hays Hammond, the American mining engineer, and finally the Boer War - all were intimately associated with the development of the South African diamond industry.

Very important deposits were later found in Southwest Africa, at the time a German colony; in Belgian Congo; in Angola; in the Gold Coast Colony; French Congo; Tanganyika; Sierra Leone; and most recently in newly discovered placers in the Union of South Africa and Cape Colony.

Physical and chemical properties:

The diamond is the hardest substance known and is designated as 10 in Mohs' scale. In Gems and Gem Materials by Kraus and Holden it is stated that diamonds show a variation in hardness according to locality. Stones from Borneo and Australia are the hardest; those from South Africa are the softest. The specific gravity is close to 3.5 when crystals are pure. The carbonado variety ranges from 3.15 to 3.29, according to Dana.

Diamonds crystallize in the isometric system and commonly occur as octahedrons (8 sides) and dodecahedrons (12 sides) or in combinations of these forms. Distortion, rounding, and twinning are usual habits. Octahedral cleavage is perfect, this property being of major importance to diamond cutters.

Stones vary in color but the most common variety is white, sometimes with pale tints of yellow or brown. Red and blue diamonds are rare. Carbonados or "black diamonds" are dark brown in color. The "blue-white" stones - those which are transparent with a blue tint - are prized highly.

Diamonds range from transparent to opaque. Only transparent or nearly transparent stones are valuable as gems. All others are used in industry. Both index of refraction and dispersion are high. Luster of the rough stone is dull; the cut stone is adamantine and, of course, brilliant. In fact, the name adamantine is derived from adamas, the name given to diamonds by the ancients. Hence the word adamant. The diamond is transparent to X-rays; paste imitations are not. The mineral is a good conductor of heat but a poor conductor of electricity.

Chemically the diamond is pure carbon. It is not affected by acids.

Geological associations:

Diamonds have been found in pipes and dikes of the ultrabasic igneous rock, peridotite, in andesitic breccias, and in placers.

The pipe deposits of commercial importance are almost exclusively in South Africa. Here the diamond-bearing rock is called kimberlite and is generally a serpentinized, magnesium-rich peridotite. Of the known occurrences of kimberlite only a few contain diamonds. Owing to surface concentration, values in the kimberlite pipes decrease with depth. The rock weathers readily, the weathered portion being called "yellow ground." Below this altered zone the partly weathered and unweathered rock is called "blue ground" because of its color. In Economic Geology of Mineral Deposits by Lilley it is stated that in 1904 at the Premier Mine the average recovery from 1600 pounds of rock was 0.798 of a carat, while in 1929 the comparable recovery was 0.164 of a carat.

No satisfactory theory concerning the origin of carbon in the igneous rock and the formation of the diamonds has been submitted. Obscure also is the reason for the occurrence of diamonds in some kimberlite bodies and not in others. Lilley¹ states that, according to conclusive evidence, the igneous action which formed the kimberlite bodies was

¹ Idem.

of the explosive type. The possibility that the origin of the diamonds is connected with underlying rocks has been suggested; also that there may be a genetic relationship between the diamond and the carbonaceous shales surrounding the igneous rock. Artificial diamonds of minute size have been made in the electric arc. Infinitely greater temperatures undoubtedly obtain in deep-seated magmas.

Although the specific gravity of the diamond is only a little greater than that of the other minerals with which it is associated, this difference together with its hardness and its resistance to chemical action results in the formation of diamond placers both by stream and marine action. Wind action is also reported to be an influencing factor in some placers. Some of the deposits are undoubtedly formed by the re-working and reconcentration of alluvial deposits formed in earlier time. Although the kimberlite mines formerly accounted for a considerable part of South African production, they were closed due to war conditions. Present production is wholly from placers in various parts of the world but mainly from Africa.

Sources of supply:

As stated above, India was the main source of diamonds in ancient times, but its present day production is inconsiderable. Borneo has been a small producer for centuries. Discovery of diamonds in Brazil made that country the main source of new stones for more than a century. Production comes from the states of Minas Geraes and Bahia. With the discoveries in South Africa and later in the Congo and Gold Coast, Africa became the great center of world production. In recent years the Belgian Congo region has been by far the most prolific of all the districts in Africa, but this region's proportion of industrial diamonds is relatively large.

A moderate production is maintained from stream placers in British Guiana, and some diamonds have been found in Venezuela and Colombia. Mexico has produced a few stones.

In 1906 diamonds were discovered in Pike County, Arkansas, in a rock quite similar to kimberlite. According to Kraus and Holden¹ about 10,000 stones have been recovered from this locality, the largest of which weighed 40.22 carats. Single diamonds have been found in several other states in this country. Diamonds have reportedly been found in Idaho and Oregon in connection with the recovery of platinum in gold placers.

A small production has been maintained in Australia principally from New South Wales. Some stones have been found in other localities chiefly in connection with gold placer mining.

In Russia diamonds were found in stream gravels in 1829. There has since been a small production chiefly in connection with recovery of gold. New discoveries were reported in 1938 and 1939 in the Yenisei and Kola regions, but only a relatively few diamonds were recovered.

The following world production for 1941 by countries, arranged in order of their importance, was obtained from the U. S. Bureau of Mines Minerals Yearbook.

<u>Country</u>	<u>Metric carats²</u>
Belgian Congo	6,106,000
Sierra Leone	850,000
Angola	787,000
Gold Coast (exports)	743,000
Brazil	325,000
Union of South Africa	112,300
South-West Africa	46,614
French West Africa	35,000

¹ Op. cit.

² A metric carat is 200 milligrams or 0.2 of a gram or 3.086 grains troy. Not to be confused with the carat used to express fineness of gold which is 1/24 part; that is, 14-carat gold is 14/24 pure gold.

<u>Country (cont.)</u>	<u>Metric carats (cont.)</u>
British Guiana	27,000
French Equatorial Africa	20,000
Tanganyika (estimated)	1,750
Other countries ¹	34,350
<hr/>	<hr/>
Total World production	9,088,014
Total African production	8,701,664

Economics:

Diamonds are classified according to physical properties into the gem varieties, bortz or bort, ballas, and carbonado.

Gem stones must be well crystallized and transparent or nearly transparent. Expert cutting develops the brilliancy of the gem.

Bortz, or bort, is the name given to poorly crystallized stones of dark color, often with fibrous structure. The name is also given to fragments unfit for gem material.

Ballas is the name given the hard tough masses of very small diamond crystals which are arranged somewhat concentrically.

Carbonado, also called carbon and black diamond, is an opaque, black, dark brown, or grey diamond. It possesses no cleavage and is characterized by its toughness. Carbonados were formerly widely used in diamond drilling. Bortz is now replacing carbonado to a considerable extent. The principal source is Bahia, Brazil.

In ancient times diamonds were owned only by kings or families of great wealth. Gradually, because of their indestructability and the continued increase in supply of new stones, possession of diamonds became somewhat more common, but with little decrease in popular regard. Improvement in the art of cutting was an important factor in popularizing the gem.

During the past century, production has increased tremendously. Value of annual production in the last of the 18th and first of the 19th centuries was from \$2,000,000 to \$4,000,000; in the late 20's it rose to \$85,000,000. After the depression struck, production dropped but in the late 1930's it was increasing up to the time of World War II. In 1939 production was approximately 11,330,000 carats valued at about \$39,270,000. It has been estimated that total world production has approximated 300,000,000 carats, or over 66 tons.

It is reported that only about one quarter of a normal year's production is colorless gem material, and only about 5 percent of this quarter is made up of fine rough stones weighing 2 carats or more. The U. S. Bureau of Mines states that in 1941 gem stones represented 22 percent of the total world production.

The sale of diamonds to the trade is very closely controlled. The Diamond Trading Company, an English corporation, controls the sale of about 95% of the world production. Formerly the diamond cutting industry centered in Belgium and Holland. At the start of the European conflict some cutters escaped but most of them were unable to leave the Low Countries and France. Several hundred cutters were able to reach New York, which is now the leading diamond cutting center.

The past several years have seen a tremendous increase in the use of industrial diamonds. Mineral Industry states that in the 1920's the average annual importation of industrial diamonds into the United States was 38,500 carats. In 1939 imports were 3,568,730 carats. According to the U. S. Bureau of Mines, the consumption of industrial diamonds in 1942 was expected to be about 7,500,000 carats. Expansion in diamond core drilling, in use of diamond-set tools, of diamond dies for fine wire drawing, and use in bonded wheels

¹ Includes Borneo, India, Australia (New South Wales), Liberia, U.S.S.R., and Venezuela.

and tools, together with various other uses where the best abrasive obtainable is demanded, all have contributed to the increased consumption of industrial diamonds. The application of powder metallurgy to forming of small bort in diamond drill bits has been an important development in the industry.

Prices:

The following table from Mineral Industry (1939) gives unit prices of diamonds (per carat) for 1929 to 1939 inclusive.

	<u>Rough</u>	<u>Cut</u>	<u>Industrial</u>
1929.....	\$28	\$101	\$87
1930.....	27	79	19
1931.....	45	59	15
1932.....	38	43	6.48
1933.....	53	47	4.79
1934.....	63	48	5.40
1935.....	54	47	4.50
1936.....	64	51	3.71
1937.....	80	56	3.47
1938.....	78	51	3.02
1939.....	52	56	2.73

In 1941 average price per carat of industrial diamonds was \$2.55 (U. S. Bureau of Mines Minerals Yearbook).

References:

Minerals Yearbook, 1941, U. S. Bureau of Mines.

Gems and Gem Materials, Kraus and Holden.

Economic Geology of Mineral Deposits, Ernest R. Lilley, 1936.

Industrial Minerals and Rocks, American Inst. of Mining and Metallurgical Engineers, 1937.

The Mineral Industry, 1939.

CLEARING HOUSE

- 79 CH Philip S. Hoyt, Van Horn, Texas, desires to obtain workable deposit of yellow ochre. An inspection sample should be sent to Mr. Hoyt. If sample is satisfactory an examination will be made.
- 80 CH Mr. John W. Opp, Jacksonville, Oregon, desires to lease his property consisting of 373 acres patented, known as the Opp mine, located about 1½ miles west of Jacksonville in western Jackson County. Has produced about \$400,000 in gold. Over 10,000 feet of development work done, most of which is still open. All workings have track and pipe; plenty of water for milling; electric power line at property; up-to-date mine assay map available.

MERCURY PRODUCTION IN THE UNITED STATES IN 1943¹

The trend of production of mercury in the United States was sharply upward after the outbreak of war in Europe in 1939, and the uptrend has been continuous ever since, according to the Bureau of Mines, United States Department of the Interior. Preliminary data for 1943 indicate that the output for that year amounted to about 53,500 flasks, compared with 50,846 in 1942; it was the largest annual production since 1881.

The following table gives a comparison of preliminary figures for 1943 with final ones for 1942. The 1943 totals are estimates based on monthly reports for mines that accounted for about 95 percent of the 1942 production.

Mercury produced in the United States in 1942 and 1943
(estimated), in flasks of 76 pounds

State	:	1942	:	1943
Arizona	:	701	:	600
Arkansas	:	2,392	:	1,600
California	:	29,906	:	35,000
Nevada	:	5,201	:	4,900
Oregon	:	6,935	:	4,800
Alaska, Idaho, Texas, Utah and Washington	:	5,711	:	6,600
		50,846		53,500

As will be seen from the table above, the favorable production record for 1943 was made possible mainly by expansion in output of California mines. The increased amount produced in California more than offset losses in Oregon, Texas, Arkansas, Nevada, and Arizona. Noteworthy production gains were also made in Idaho and Alaska in 1943.

The record-breaking prices for mercury during the past 4 years have caused the opening of several new mines and the reopening of numerous idle ones. In 1939, 107 mines reported mercury production whereas in 1943 the number of active producers probably totaled 175. The number in 1943 represents a recession from the peak of 197 reached in 1941, some properties having closed due to exhaustion of ore reserves and other causes. In periods of what are termed "normal" prices a relatively few properties dominate mercury production in the United States. This condition changes when prices are high and more properties attain larger production. For example, 16 mines produced 88 percent of the total output in 1939, compared with 34 mines (more than twice as many) that accounted for just over 90 percent in 1943.

* * * * *

The average quoted price for mercury at New York stood at \$196.00 a flask from November 1942 until the last week in September 1943. The average monthly quotation was \$195.72 for September, \$195.00 for October, \$193.70 for November and \$190.08 for December 1943.

¹ Reprint of part of U. S. Bureau of Mines Mineral Market Report No. MMS 1120 released January 14, 1944.

STATE DEPARTMENT OF GEOLOGY & MINERAL INDUSTRIES
Head Office: 702 Woodlark Bldg., Portland, Oregon

State Governing Board

W. H. Strayer, Chairman Baker
Niel R. Allen Grants Pass
S. H. Williston Portland

Earl K. Nixon Director
F. W. Libbey Mining Engineer
John Eliot Allen Geologist
H. C. Harrison Chief Chemist

State Assay Laboratories

714 E. H Street, Grants Pass

2102 Court Street, Baker
Norman S. Wagner Field Geologist

WHAT'S IN A GLAZE?

Introduction

Any piece of tableware, be it Wedgewood's best, Spode's finest, or just that cereal bowl obtained with a box-top and ten cents to cover postage, is essentially a baked clay body covered with a glaze. A glaze is a coating applied to a ceramic body. The coating becomes a glass on firing and provides an impervious covering as well as decoration for the product.

The development of fine china and glazes has tested the ingenuity of man throughout the ages, and the number of glaze formulas used since the beginning of ceramic history is infinite. There are several reasons for this: First, because of the wide variety of clays and ceramic body mixtures, it has been necessary in most cases to develop new glazes or alter known glazes to fit each new ceramic body; second, before the discovery in Europe of white-burning clays the desire to copy the white porcelain of the Chinese brought about the development of majolica, faience, and other ingenious imitations; third, for centuries, both glaze and body formulas were regarded as trade secrets, and each craftsman was forced to develop his own compositions; fourth, the artist has always been called upon to produce new and different effects in order to please the buying public; and finally, within the last century glazed ware has been used for wall tile, insulators, sanitary ware, chemical ware, etc., in which specific requirements such as hardness, resistance to moisture, frost, heat and resistance to chemical action had to be satisfied.

Exhaustive technical studies of the effects of various materials as well as methods of preparation, application, and firing on the properties of glazes have enabled workers to fit a glaze to a body more perfectly. Thus scientific rather than hit-and-miss methods are now used to make glazes which must meet specific requirements.

Glazes in general

Most glazes are prepared by mixing the constituents with water until the consistency of cream is reached. The glaze "slip", as the mix is called, is then applied to the body by spraying or dipping. The consistency of the slip is controlled by adjusting its specific gravity which should be about 1.75. Gelatin, dextrine, or gum tragacanth is often added to the glaze slip to improve the adherence as well as to add smoothness of flow. When the glaze is thoroughly dried, the ware is fired. An exception to these methods of application is the salt glaze, which is formed by vaporizing common salt in the kiln during the firing of the ware.

The composition of the fired glaze is different from the composition of the raw glaze. Likewise the composition of a glaze applied to a body and fired differs from the composition of the glaze when fired alone. The chemical changes which take place in the firing

are not fully understood. Blakeley's work, "The Life History of a Glaze", describes the physical changes which occur during firing. In Blakeley's experiments, specimens to which a whiteware glaze had been applied were fired to various temperatures and quenched. Photomicrographs of cross-sections of these pieces showed the following results in the glaze:

- 750° C. Large holes or pores, undoubtedly the remains of space between particles in the raw glaze, were noted. Quartz and feldspar particles were readily determined. A definite boundary between glaze and body could be seen.
- 900° C. The pores had completely disappeared and the larger holes had formed bubbles. Feldspar grains were being dissolved by the glass which had been formed.
- 1025° C. Very little crystalline material was left.
- 1095° C. Most of the air bubbles had escaped.
- 1100° C. Quartz was completely dissolved.
- 1145° C. Erosion of the body by the glaze was definitely shown.
- 1150° C. All bubbles had escaped and a clear glass was observed.

The above investigation gives a general picture of the progressive changes which occur in a glaze during firing, but these changes do not take place in all glazes at the same temperature.

The ceramist refers to heat treatment in terms of cones, which are "pyramid shaped fusible bodies of progressive softening order, employed as a guide in determining the finishing point of a ceramic kiln."* The table below gives the cone temperatures referred to in this paper, converted to degrees Centigrade and Fahrenheit.

<u>Cone Temperature</u>	<u>Degrees C.</u>	<u>Degrees F.</u>
010	890	1634
09	930	1706
08	945	1733
07	975	1787
06	1005	1841
05	1030	1886
04	1050	1922
03	1080	1976
02	1095	2003
01	1110	2030
1	1125	2057
2	1135	2075
3	1145	2093
4	1165	2129
5	1180	2156
6	1190	2174
7	1210	2210
8	1225	2237
9	1250	2282
10	1260	2300
11	1285	2345
12	1310	2390
13	1350	2462
14	1390	2534
15	1410	2570

* Lange, Handbook of Chemistry and Physics, 4th ed., 1941, p. 692.

Classification

Orton's classification of glazes is widely accepted and will be used in the following discussion. Any discussion of glazes should include a brief consideration of the bodies to which the glazes are applied. Glazes are classed either as hard or soft; and as a general rule, hard glazes are applied to hard-fired or high-temperature bodies, and soft glazes to soft-fired or low-temperature bodies.

Hard Glazes

Hard-fired wares include porcelain and stoneware. In appearance porcelain is light and graceful while stoneware is strong and forceful. Both types of ware are commonly once-fired. The body and glaze of both types mature within the same temperature range. For this reason the alumina-silica ratio of the body usually approaches the alumina-silica ratio of the glaze, and glaze defects may be more easily avoided. The art of making porcelain requires great skill, as the high temperature brings out flaws which may have developed in the forming process. Stoneware, however, is more easily made than porcelain because of its coarser texture and fired porosity, as compared to the vitreous nature of porcelain. This does not necessarily detract from the value of stoneware, for each type of ware has its own suitable forms and uses.

Porcelain glazes

Porcelain glazes consist of alkaline or alkaline-earth silicates free from reducible oxides. Lead or boron may not be present. Porcelain glazes have high viscosities, high fusion points, and high critical temperatures. The firing temperatures of porcelain glazes range from cone 8 to cone 15. A simple porcelain glaze is made by mixing the following:

Feldspar	167 parts
Whiting	60 "
Kaolin	26 "
Flint	84 "
Zinc oxide	8 "

Stoneware glazes

Stoneware glazes consist of alkali or alkaline-earth silicates, and are free from reducible oxides. Stoneware glazes often possess a matte rather than a glossy surface, and the firing range of these glazes lies between cone 8 and cone 15. The three main types of stoneware glazes are salt glazes, slip glazes or engobes, and Bristol glazes.

Salt glazes

Salt glazes are immediately recognized by their characteristic orange-skin texture as on glazed sewer pipe. Salt glazing is a simple process. When the temperature of the kiln is between cone 5 and 8, common salt is thrown into the flame and is immediately volatilized. The vapor is retained in the kiln by temporarily closing the stack dampers. The salt vapor reacts with the clay body to form a glaze. Not all clays will take a salt glaze, and this question may be determined only by experiment.

Engobes

Slip glazes or engobes are often natural clays. Engobes were originally white coatings applied to crude, dark-colored clays to produce a ware as nearly as possible like porcelain. Colored decoration is frequently added to the opaque engobe before firing. After the first firing the piece is covered with a clear glaze and refired. A typical engobe has the following composition:

Clay	50%
Feldspar	12%
Flint	38%
Whiting	2%
Sodium Carbonate	1%

Bristol glaze

The Bristol glaze is a compounded glaze that burns white or transparent. It is often artificially colored and is usually high in alumina and zinc oxide. The alumina to silica ratio is about 1:7. If the zinc oxide goes into solution, the glaze is transparent, but if the zinc oxide is in suspension the glaze is opaque. A typical stoneware Bristol glaze has the following composition:

Feldspar	185 parts
Kaolin	56 "
Flint	39 "
Whiting	33 "
Zinc oxide	27 "

Soft glazes

Soft glazes consist of raw lead glazes and whiteware glazes. The temperature range of the soft glazes lies between cone 010 and cone 7. The raw lead glazes are used mainly on yellow ware, roofing tile, terra cotta, decorative brick, and ornamental pottery. Whiteware glazes are used on the higher grades of ornamental pottery, white pottery, and glazed tiles; the whiteware glazes are too expensive to be used on cheaper ware.

Lead glazes

Raw lead glazes are composed of alkalis, alkaline earths, and heavy metal silicates. They are boron-free. Lead is the main fluxing constituent and is usually introduced as red lead to minimize danger of poisoning. Although toxic, white lead is sometimes used. The advantages of raw lead glazes are:

- (1) The glazes have wide firing ranges.
- (2) The lead silicates which are formed are fusible at low temperatures.
- (3) Lead silicate is relatively insoluble.
- (4) The glazes have a low surface tension and low viscosity which tend to produce a smooth glaze.
- (5) Lead compounds have high fluxing power.

The disadvantages of raw lead glazes are:

- (1) The glazes are soft.
- (2) Lead compounds are toxic.
- (3) The glazes have a tendency toward "crazing", which is the development of fine cracks.
- (4) The physical properties of the glazes are easily affected by the gases in the kiln.

The most important forms of the raw lead glazes are:

- (1) The Rockingham glaze which is a dark brown glaze obtained by additions of manganese dioxide and iron oxide;
- (2) The jet glaze which is black and is used for jet pottery as well as for roofing tile;
- (3) The majolica glaze which was one of the earliest imitations of Chinese porcelain (this glaze is now used as a decorative glaze for ornamental ware);
- (4) The colorless raw lead glaze which serves as a base to which other colorants may be added.

A glossy transparent glaze has the following batch composition:

Red lead	160 parts
Whiting	20 "
Feldspar	56 "
Kaolin	26 "
Flint	40 "

A matte glaze which matures at cone 02 has the following batch composition:

White lead	129 parts
Whiting	30 "
Feldspar	111 "
Calcined kaolin	22 "
Kaolin	11 "

Whiteware glazes

Whiteware glazes consist of the alkalis, alkaline earths, and heavy metal borosilicates. Although lead is always present, it is not the principal flux ingredient. The whiteware glazes are always fritted, the purpose of which is to render insoluble the soluble ingredients of the glaze such as borax, boric acid, and soda ash. Fritting is accomplished by melting these soluble constituents with sufficient whiting, feldspar, and flint to form a glass. The molten glass is quenched in water, and the resulting product is called a frit. This product is ground and added to the remaining glaze ingredients. The glaze is then ready for application. The most important varieties of the whiteware glaze are:

- (1) colored tile glazes;
- (2) enamels or opaque glazes, which usually contain tin oxide or its equivalent;
- (3) ordinary whiteware glazes, which are used in French frit porcelain, English bone china, American semi-porcelain, and American vitrified china.

A bright fritted glaze has the following batch composition:

<u>Frit</u>		<u>Glaze</u>	
Borax	114 parts	Frit	117 parts
Whiting	60 "	White lead	64 "
Soda ash	10 "	Zinc oxide	12 "
Feldspar	56 "	Feldspar	28 "
Flint	78 "	Kaolin	13 "
		Flint	60 "

Colored glazes

Colorless glazes would become monotonous. Color is introduced either into the base glaze or into the ceramic body itself. Five types of commercial ceramic coloring agents together with the temperature range over which they are used are:

- | | |
|----------------------------|------------------|
| (1) Vitreous enamel colors | 1250-1550° F. |
| (2) Glaze stains | cone 010-cone 20 |
| (3) Body stains | cone 9-cone 12 |
| (4) Underglaze colors | cone 06-cone 4 |
| (5) Overglaze colors | cone 014-cone 06 |

Vitreous enamel colors are used where the enamel or glaze is applied to metal.

Glaze stains can be used on nearly all ceramic ware. These stains are mixtures of raw and calcined material in which the color is developed before the stain is added to the glaze.

Body stains are very costly and their range is less extensive than that of the coloring oxides. The stains may be calcined mixtures or natural earths such as ocher and umber which are incorporated in the ceramic body itself.

Underglaze colors, or colors applied over the body before glazing, are used in hotel china. The underglaze color is developed at higher temperatures than the overglaze which serves to protect the underglaze. Underglaze colors are protected from chemical action and are permanent. The choice of colors is limited, and the coloring agents are difficult to use since they must be precalcined and have a high softening point.

Overglaze colors consist of pre-burned glazes which are finely ground and applied to ware already glazed.

The ordinary base glaze is often artificially colored with ceramic oxides. Colors obtainable with the more common oxides under oxidizing conditions are:

Cobalt oxide	Light blue to dark blue
Copper oxide	Light green to dark green
Iron oxide	Yellow to chestnut brown
Manganese dioxide	Light purple to deep brown
Chromium oxide	Medium green to dark green
Uranium oxide	Light yellow to strong yellow
Nickel oxide	Soft brown to medium brown
Titanium oxide	Straw color

Intensity of coloring can be determined only by experiment.

Conclusion

Application of glazes to ceramic ware in the Pacific Northwest has been confined to the production of some stoneware and pottery. In addition, work with glazes has been done in a number of art studios and college laboratories. The ability to develop new glazes and to adapt nearby available raw materials as ingredients in ceramic ware is of the utmost importance. There is much to be discovered, and the use of new raw materials in ceramics opens a new field which should be thoroughly explored.

Esther W. Miller

References

- Lecture Notes of R. M. Campbell - New York State College of Ceramics.
 The Potter's Craft, C. F. Binns, D. Van Nostrand Co., New York, 1910.
 "Life History of a Glaze", A. M. Blakeley, Journal of the American Ceramic Society, Vol. 21, No. 7, 1938.
 Handbook of Chemistry and Physics, 4th Ed., Lange. Handbook Publishers, Inc. Sandusky, Ohio, 1941.

IN APPRECIATION

Don't you recall when at least once or twice in your lifetime not one but two or more events causing deep emotion have occurred within the space of a few days? The week past has been that kind of period for me.

It happens that I was born, during the 90's, in Emporia, Kansas, a town made famous by a country editor, William Allen White, and infamous by vaudevillian association with Oshkosh, Kalamazoo and other points on Main Street, mentioned with the intention of conveying the antithesis of cosmopolitanism.

There is a legend in our family which runs to the effect that at the age of two years and some months, I took off on what probably was the first exploration trip of my career. It ended, so the yarn goes, in the backyard enclosure of the W. A. White residence, with me on quite friendly terms with the White's negro maid. The mystery seems to have been how I

covered the considerable number of blocks from our cottage to the White home - whether under my own doubtful power, by thumbing a ride, or otherwise. Whenever I've heard the story it, quite plainly, was told not to suggest that any importance attached to my being found on the premises of a celebrated family. Rather it was told, always by my mother, to illustrate her contention that I possessed a constant and congenital desire to be somewhere else, and that I started early in life to demonstrate the characteristic. Judging by the number of places in which I've lived, I've been demonstrating it ever since.

About that time, say 1900, William Allen White was not a celebrity in Emporia, but he was considered one of the solid citizens in that part of Kansas. As a youngster, I went to grade and high schools in the next county-seat town south of Emporia, but I doubt if a week passed when Dad didn't refer in some complimentary manner to William Allen White - his searching analyses, his humaneness, or his interesting political observations. On certain occasions when I was a youngster I recall Dad's taking me with him to Emporia on some school business, and stopping to chat with White at the Emporia Gazette office. I remember the man as a shortish, roly-poly fellow with kindly mien and the brightest eyes, sitting at a much cluttered desk in a badly cluttered office.

William Allen White's WHAT'S THE MATTER WITH KANSAS? placed him foremost in the minds of Kansans as a keen, accurate, fearless, and very humane citizen and editor. His WHEN A MAN'S A MAN heightened his standing not only at home but wherever books are read.

When one lives closely within the influence of an important person, one is apt to gauge that person's stature without proper perspective - like guessing the height of a church from its front step. Through the years we who lived under William Allen White's local influence appreciated and revered him, but perhaps we were too close to see his full stature. In later years from across the country he shone with greater brilliance when compared with others of his calling.

I'm proud to confess to my addiction, as a youngster in school and as an adolescent, to hero worship of the person and life of William Allen White. And now, as I read of his passing a week ago, I am deeply aware of a loss that seems more personal, because of memories as a child and later, than I have any real right to claim.

And then yesterday's headlines.....Ray Clapper!

Let's go back thirty years. Have any occasions or situations in your life burned their trace any deeper into your memory than those of the first day or the first weeks of your entrance into college? Perhaps I was the more deeply impressed because I came from a country town, had never been anywhere, and therefore was frightened nearly to death at every aspect of getting started in this school of several thousand students all of whom seemed better equipped than I. Enrolling was a nightmare so agonizing that the details are somewhat confused. But my very first class at 8:00 a.m. and in freshman English was something never to be forgotten. I milled around the fatal door with other frightened sheep, then slithered in after the gong rang and sat on the edge of a chair where I could be the first one out if the going got too tough. The teacher, Miss Sarah Laird, calmed our fears slightly by giving a casual outline of the course, then suggested that if we had pencils and paper she would give us some rules to observe in writing our weekly English themes. She called off several rules pertaining to paper margins, punctuation, length of themes, and selection of topics, and then ended with the rule, "And never use a preposition to end a sentence with."

I fairly exploded - a regular Moon Mullins guffaw but with Li'l Abner Yokum innocence, in a room of perfect strangers. Both teacher and class were so taken aback with my outburst that they were struck dumb for a second. Then, to my amazement - and salvation - Miss Laird threw her head back and laughed out loud unrestrainedly like the thoroughbred she was. By that time, of course, I had realized the enormity of my crime and was trying to select a convenient crack in the floor through which to sink. The class had begun to snigger, but it was plain that they were laughing at me whereas Miss Laird had been laughing with me.

Within two weeks Miss Laird was reading my themes as exhibits, and letting me arbitrate discussions on grammatical points, and it was "Mr. Nixon" this and "Mr. Nixon" that. Then, after some of the misfits had been weeded out or had gone back to their homes, our English section was combined with another of Miss Laird's to form a single class of some twenty-five. And then it came to be "Mr. Nixon" this and "Mr. Clapper" that. I had a rival, a nemesis. My star stopped shining so brightly; in fact, it seemed to me that it dimmed somewhat by comparison. Clapper's themes were read as often as mine, sometimes more often. Our progress began taking on slightly different patterns. In matters of grammar we were equal. Either of us settled arguments for the class, and we rarely argued between ourselves. We'd both evidently had the same excellent training in grammar. (Lord, how I miss it now!) But in rhetoric Clapper distinctly had the edge on me. And his themes had a consistent high quality, excellent mechanical construction, smooth flow of words, and orthodox style. At times I'd turn out a job that was an inspiration, and Miss Laird would go to town praising it; at times my stuff was terribly mediocre. Never did I attain the consistency Clapper did.

I came to know Ray Clapper well and to admire him greatly. Then, in 1913, he was of slimish build but wiry, and he walked with a very slight stoop. I recall distinctly his longish neck and prominent Adam's apple but his voice I remember best. It then was hoarse and crackly. Often we sat outside that first-built wing of the "Ad" building at the University of Kansas, and gabbled about some point of English or rhetoric. He, a few years older than I, had stayed out after finishing high school and had worked in a newspaper office. That accounted for his excellence in writing.

For twenty years now, from various parts of this country or from one or two other countries, I've read his column when I could get it, and I never ceased to admire his plain common sense, his directness, his honesty. I didn't always agree with him - although mainly, I did. But I doubt if any columnist ever attained Clapper's consistency as a reporter. That's something he brought from Kansas. Now, I'm going to miss him - awfully, as I'm going to miss that other great Kansan.

In telling reminiscences - those intimate "I remember when" stories - the teller is likely to spill over slightly and unconsciously overtell his own part in the play. Guess that's just because we're human. So, if I've let my hair down a bit too much, or have brought out of the past an anecdote or two of the kind one would ordinarily forever keep locked in his book of memories, it is because when I, like some other humans, experience a sorrow, that feeling translates itself into a certain mellowness. And that mellowness in turn finds expression in my desire to write down - for someone else to share - the basis of my sorrow. In a way that may be a bit unfair, although I have no apology. Anyway that's how it happened.

E.K.N.

81 CH Cuban-American Holdings Limited, 416 Balboa Building, San Francisco, is interested in obtaining supplies of asbestos particularly amphibole or tremolite types. Anyone wishing to sell asbestos should communicate with this company. A five-pound sample should be sent for testing purposes together with information on location, amount which could be shipped, and shipping point. If deposit may be leased all conditions should be submitted.

STATE DEPARTMENT OF GEOLOGY & MINERAL INDUSTRIES
Head Office: 702 Woodlark Bldg., Portland, Oregon

State Governing Board

W. H. Strayer, Chairman Baker
Niel R. Allen Grants Pass
S. H. Williston Portland

Earl K. Nixon Director
F. W. Libbey Mining Engineer
John Eliot Allen Geologist
H. C. Harrison Chief Chemist

State Assay Laboratories

714 E. H Street, Grants Pass
W. A. G. Bennett Field Geologist

2102 Court Street, Baker
Norman S. Wagner Field Geologist

BISMUTH

Introduction:

Several metals are outstanding in some particular characteristic which makes them extremely useful, even essential, in our daily life. Bismuth is such a metal. In normal times the supply is adequate and is more or less controlled by a few large companies, both domestic and foreign. They are able to balance supply and demand and it is reported, that because of ample supplies and close control, a lowering of price would not increase the use of the element.

Bismuth is a relatively uncommon metal known generally for its medicinal use; its metallurgical applications, though enhanced greatly because of the war, are not as well known. At the present time bismuth is one of the few metals placed by the War Production Board in Group I of "the most important materials essential to the war effort". Group I is defined as those materials, supply of which is insufficient to satisfy war plus essential industrial demands.

History:

According to early writers, bismuth may have been known to the ancients but was believed to be an undeveloped form of tin or lead. In 1530 Agricola described the metal under the name of "Bisemutum". Libarius wrote of the metal in his "Commentariorum Chymicorum" (1606) and stated that it was used to soften tin, but he confused bismuth and antimony. Other writers of this period had no clear ideas concerning bismuth as a true metal. J. H. Potts in 1739 first demonstrated characteristic reactions of bismuth, and these were further demonstrated by Geoffrey (1753) and by Bergmann (1780). How the medicinal qualities of bismuth salts were discovered is unknown, but this knowledge dates from the Middle Ages. Libarius discovered bismuth subnitrate and its efficacy in treatment of diseases of the intestinal tract for which medicinal use it is still applied. The use of the metal in industry is of relatively recent time.

Mineral Resources of the United States first mentions bismuth in the volume which reported on mineral production in 1882. After briefly describing occurrences in Colorado, Utah, and Arizona, the report states that production in the United States "has thus far been of no importance".

In the report for 1883-1884 mention is made of a little ore, "said to have carried 7 percent metal," which was shipped from the Bismuth mine in Beaver County, Utah, in 1871. It also states that supplies of bismuth came principally from mines in Saxony, Hungary, Baden, Cornwall, and Australia, and that total production was small. Market price was given as \$2.00 a pound. Domestic imports were listed beginning in 1868 (no weight given) valued at \$30,149. In 1882, 64,837 pounds valued at \$111,087 was imported.

In the Mineral Resources report for 1885 it is stated that one ton of bismuth was produced experimentally at Loveland, Colorado, during 1885 and that commercial production would probably start in 1886. It mentions that the uses of the metal "are limited".

Domestic consumption of bismuth increased progressively in the last part of the last century but there is a gap in the ^{bismuth} reports of Mineral Resources after 1885. In 1902 it was reported that, while there was no production in 1902, output for 1901 was 318.6 short tons of bismuth ore assaying from 4 to 12 percent bismuth and from 1 to 2 ounces of gold to the ton. All production was from Colorado. It mentioned that production and price of bismuth and its ores "continue under the control of Johnson, Mathey & Company, Limited, and the government of Saxony." Domestic imports in 1902 were reported as 190,837 pounds valued at \$213,704, compared with 165,182 pounds valued at \$239,061 in 1901.

In 1904 it was reported that "the price of the refined metal is kept so low by the combination controlling the business that profitable mining of our domestic ores is practically out of the question." Only 5,184 pounds of ore valued at \$314 was reported marketed in that year.

In 1905 the report states that the London price of the metal was reduced by the controlling combination from \$2.43 to \$1.22 a pound. Mention is made of resumption of work at the Ballard mine, Leadville, Colorado; of the large output in Saxony; of development in Tasmania of an enormous deposit of tin-bismuth-copper ore; of the important sources of supply in Bolivia and Mexico; of the extraordinary demand for medicinal and surgical purposes because of the Russo-Japanese war; and of marketing of 2,288 pounds of domestic metal valued at \$4,187.

The 1908 report first mentions recovery of bismuth in lead refining by two companies - the United States Metals Refining Co. and the Monsanto Chemical Co. Price of the metal was quoted at \$1.75 a pound in London, and it was stated that the price had been raised and maintained after the low price reported in 1906 had extinguished competition.

In 1910 production consisted of the by-product from the United States Metals Refining Company's Grasselli, Indiana, plant together with a few tons of bismuth-bearing gold ore from Leadville, Colorado. Domestic imports were 198,174 pounds valued at \$332,668. Price of the metal rose during the year from \$1.70 to \$2.15 a pound.

The 1912 report mentions the American Smelting and Refining Co. (in addition to the United States Metals Refining Co.) as a producer of bismuth from lead refining operations. The following is quoted to show the feelings of the trade at that time:

"Heretofore large buyers have claimed that they could not safely buy of American producers of bismuth, for should they do so and should the American producers be unable to continue supplies the agents of the foreign sellers would thereafter refuse to sell bismuth to them, and the lack of a constant supply has always been a possibility to be feared."

The 1911 report describes in considerable detail the European combination which fixed the price of bismuth and allotted the trade territory to kill competition. It is stated in the report that flue dust of the Anaconda Washoe smelter amounted to 76.8 tons and carried 1.15 percent bismuth trioxide equivalent to 1,580 pounds of bismuth a day, and that this amount was not considered worth saving. A table is given showing recoveries of bismuth from electrolytically refined blister copper at various copper smelters in the United States, Mexico, Peru, and Tasmania. The recoveries range from 0.33 to 27.3 pounds of bismuth to the ton of blister copper. The lowest recovery was at Steptoe, Nevada; the highest at Mountain City, California. Imports during 1911 were 117,747 pounds valued at \$213,257.

Conditions did not change materially between 1911 and the start of World War I. In 1915 domestic imports fell off sharply, dropping in that year to 44,362 pounds valued at \$108,288. It is stated in the 1915 report that the production in this country was in the hands of companies which were so strong and whose bismuth supplies were so certain that the control formerly exercised by the European combination had been considerably weakened.

In 1918 imports jumped to 135,700 pounds valued at \$277,273 compared with 69,250 pounds valued at \$142,300 in 1917.

After World War I control of prices apparently returned to the English firm of Johnson, Matthey & Co. Although production statistics were not published, it was estimated that domestic sales in 1921 did not exceed 232,000 pounds valued at \$396,000. In March 1921 the price dropped to \$1.50 a pound where it remained for the balance of the year. Imports were 94,085 pounds valued at \$114,891.

In 1922 price of the metal jumped to \$2.45 a pound. The 1922 Mineral Resources report states that in normal times bismuth ores and concentrates without other metals should contain at least 15 percent of metallic bismuth to be marketable. Bismuth purchased in the domestic market was estimated at 226,385 pounds (including some imported metal) at a cost to the consumer of \$2.26 a pound. Imports were estimated as 121,505 pounds valued at \$239,777.

The succeeding reports of Mineral Resources do not contain ^{bismuth} production statistics, and the history of the domestic industry is generally brought up-to-date under the later heading of "Statistics and Prices."

Physical properties:

Bismuth is a soft, heavy, lustrous metal, silvery white in color with a reddish tinge and subject to tarnish. Its specific gravity is 9.8 in the solid state and 10.06 when liquid. The specific gravity of the liquid phase decreases to 9.6 with increase of temperature to 650°C. The metal is brittle and granular; the fracture is coarsely crystalline, and crystal habit is hexagonal rhombohedral. Melting point is 271°C (520°F); boiling point is from 1090° to 1450°C. Bismuth has the nearly unique property of expanding on solidification. Heat conductivity is the lowest of any metal except mercury; electrical conductivity is very low - only 1.19 percent that of silver at 13.8°C. Unlike most metals the electrical conductivity of bismuth is greater when melted than in the solid state. It is the most diamagnetic of any metal, that is, it is repelled instead of attracted by a magnet.

Chemical properties:

In the periodic table bismuth is grouped with antimony; many properties of the two metals are similar. Air at ordinary temperatures does not attack bismuth, but at higher temperatures the metal takes on a coating of dark-colored oxide. Bismuth decomposes steam slowly, liberating hydrogen; at room temperature water has little effect on the metal. Bismuth is easily dissolved by nitric acid; it is dissolved by hot concentrated sulphuric acid with emission of sulphur dioxide. Hot concentrated hydrochloric acid dissolves bismuth slowly. Chlorine, bromine, and iodine combine directly with bismuth to form the halides. Likewise sulphur combines with molten bismuth to form the sulphide (Bi_2S_3). Bismuth sulphide is precipitated from solution by hydrogen sulphide and all the soluble sulphides. Bismuth nitrate obtained from nitric acid solutions is the most important bismuth salt.

Uses:

Normally the most important use of bismuth is in pharmaceutical preparations. A common use of its compounds is in X-ray examination of the digestive tract and in the treatment of digestive disorders.

The low melting point of bismuth forms the basis of a number of useful alloys. The property of expansion on solidification is also adapted to counteract shrinkage in certain applications. Bismuth combined with lead, tin, cadmium, and antimony forms alloys used in sprinkler and other fire-protection apparatus, solders, and electrical fuses, all of which require a low melting point. Alloys containing bismuth are used for bearing metals and die castings, and for taking impressions of wood cuts, coins, and various fragile objects where sharp delineation is required. A small percentage of bismuth added to certain metals and alloys improves machinability.

The following table* gives characteristics of various low-melting point alloys:

Fusible Bismuth Alloys.

Fusible below the boiling point of water, 212°F.

	Bismuth, melting point 520° F.	Lead, melting point 621.1°F.	Copper melting point 1981.5°F.	Tin, melting point 449.4°F.	Cadmium, melting point 609.6°F.	Mercury, melting point 37.7°F.	Antimony, melting point 1,166°F.	Melting point of alloy, °F.
Charpy's eutectic	8	5	---	2½	---	---	---	204°
Newton's metal	8	5	---	3	---	---	---	201°
D'Arcet's metal	8	4	---	4	---	---	---	199°
Rose's metal	8	8	---	3	---	---	---	174°
Onion's mercuric	8	5	---	3	---	1½	---	170°
Lipowitz's metal	8	5	---	2	1	---	---	150°
Lipowitz's mercuric	8	4	---	2	2	1	---	143°
Wood's metal	7½	4	---	2	2	---	---	140°
Guthrie's eutectic	8	3	---	3	2½	---	---	(1)
D'Arcet's mercuric	8	4	---	4	---	20	---	113°

(1) Very fusible.

Bismuth minerals:

The most important bismuth minerals are the native metal, the sulphide (bismuthinite), and bismuth-bearing lead sulphides. Oxidized minerals are bismite ($\text{Bi}_2\text{O}_3 \cdot 3\text{H}_2\text{O}$), bismutite ($\text{Bi}_2\text{O}_3 \cdot \text{CO}_2 \cdot \text{H}_2\text{O}$), and some combinations with arsenic. Textbooks on mineralogy also list rather rare bismuth minerals as follows: oxychloride, silicate, telluride, tellurate, selenide, uranate, and vanadate.

Native bismuth, usually in cube-like rhombohedrons having a brilliant metallic lustre, is found in crystalline rocks sometimes associated with silver, cobalt, lead and zinc ores.

Bismuthinite (Bi_2S_3), generally massive with a fibrous structure, has a lead-gray color and streak, sometimes inclining to lighter shades with a yellowish tarnish. It is associated sparsely with some other metallic minerals in various parts of the world.

Oxidized bismuth minerals have been found concentrated in the oxidized zone of some ore deposits, notably at Tintic, Utah, and at the Great Cobar copper mine, New South Wales. Like some other metals which are affected little if at all in the laboratory by water at ordinary temperatures, oxidation of the primary bismuth minerals may occur under natural conditions, and the resultant oxides are more or less concentrated in the oxidized zone of the deposit. Bismuth oxide minerals are commonly yellowish in color and powdery.

*Credited by Mineral Resources of the United States, 1917, to B. Dunstan, Queensland mineral deposits (bismuth); Queensland Gov. Min. Jour. January, 1917.

Sources:

Domestic bismuth is derived almost entirely from secondary refining operations at lead and copper smelters. No deposit of record in the United States is mined for bismuth alone, but, as stated, it is an accessory constituent of some lead and copper ores mainly in Utah, Nevada, Idaho, Montana, Colorado, New Mexico, and Arizona. In 1940 the Bunker Hill and Sullivan Company started a new refinery designed to produce both antimony and bismuth from the tetrahedrite ores of the Coeur d'Alene district, Idaho.

In Canada bismuth has been produced both from the silver-cobalt ores of the famous cobalt deposits in Ontario and from the ores treated at the Trail smelter in British Columbia.

Bismuth is found as an accessory mineral in many Mexican mines, and a large part of the Mexican production is exported to the United States in ore or lead bars.

The two South American countries, Peru and Bolivia, contain the largest known sources of bismuth. They have large reserves of bismuth minerals associated with other metallic ores. In normal times these two countries could supply world demand without difficulty. Occurrences of bismuth minerals are known in Argentina, Chile, and Brazil.

European sources are mainly in Spain. Both England and Germany formerly produced some bismuth. In recent years these countries have been dominant in the marketing of bismuth but through cartels and smelting facilities rather than through mine production.

In Africa bismuth occurs with the South African gold ores and has been reported at several places in Northern Rhodesia.

Asiatic production has been largely dormant because of the war. Formerly China exported a material amount. Japan produces the metal mainly as a by-product of smelting operations. Occurrences of bismuth minerals have been reported in Burma, Korea, Siberia, and the Dutch East Indies.

Occurrences of bismuth in association with other minerals are known in various parts of Australasia. The most important deposits are in New South Wales, Queensland, Victoria, South Australia, Tasmania, and New Zealand. A small to moderate production has been maintained for many years.

It is reported that the United Nations control 80 percent of the world supply of the metal.

Statistics and prices:

Domestic production statistics are not published. Mineral Industry reported that imports, mainly in the form of metal, into the United States in 1939 amounted to 182,832 pounds - double the amount in 1938. Exports during the first eight months of 1939 were estimated to have been about 314,000 pounds compared to 225,600 pounds for all of 1938.

World production of bismuth in 1938 was estimated by Mineral Industry at about 1,000 tons. This amount has been greatly increased because of the war. It was estimated that the apparent world consumption in 1939 was about 2,600,000 pounds, of which about 500,000 pounds was consumed in the United States and 2,000,000 pounds in Europe. Probably a part of the apparent consumption went into stocks in anticipation of restricted trade.

Before the war London quotations through the firm of Johnson, Matthey & Co. governed the world market price. The few large smelting companies which control production in the United States accepted London quotations as the basis of sales made for the most part entirely in the domestic market. Because of the war, rigid government control is now exercised.

Market price just prior to the war in Europe was about \$1.00 a pound. Late in 1939 the price advanced to \$1.25 a pound where it has remained unchanged. Quotations for the pharmaceutical trade are for 99.9 percent metal, free from arsenic. According to U. S. Bureau of Mines Information Circular 6466 a typical analysis is as follows:

Silver	0.05	percent
Lead	.005	"
Copper	.007	"
Iron	.005	"
Zinc	.01	"
Bismuth	99.923	"

Prices for bismuth during the early part of the present century were generally considerably higher than at present. Just before World War I, prices were about \$2.00 a pound. In 1916 the price was \$4.00 a pound; in 1917 the price was set at \$3.50 a pound and was unchanged until the end of the war. In the 1920's quotations were generally over \$2.00 a pound. The price declined in the depression years of the 1930's to below \$1.00 and showed signs of strength only late in that period when unsettled conditions in Europe caused the trade to accumulate supplies.

The present market quotation is for metal bars in ten lots.

References:

- U.S.Bureau of Mines Minerals Yearbook, 1939.
- U.S.Geol. Survey, Mineral Resources of the United States.
- The Mineral Industry, 1939.
- U.S.Bureau of Mines Information Circular 6466.
- Textbook of Inorganic Chemistry, Partington, MacMillan and Co. Limited, London, 1937.
- Modern Inorganic Chemistry, J.M.Meller, Longmans, Green and Co., New York, 1930.
- Handbook of Nonferrous Metallurgy, Liddell, McGraw-Hill Co., New York, 1926.

ANOTHER TALL TALE OF A SOURDOUGH

James H. Batcheller, Corvallis, whose reputation for veracity is as clean and spotless as the newly fallen snow of the North Country which he loves to talk about, told us the following story, and we unhesitatingly vouch for the truth of anything Jim tells us. (Ed.).

I was talking with a lenely prospector, in a low valley 'way north of the Arctic Circle. He was one of the misfits of the horde of gold rushers who did not find anything but, in spite of that, was so gripped by the vastness of the country, he had managed to hang on in a little dugout with just one lene window, facing south.

He thought it would cheer his leneliness if, in the long hot sunlit days, he could just grow a few of the hardy flowers from his homeland in the temperate zone. He sent for a variety of seeds and started them indoors in flats, early in the spring. As soon as danger of late frosts was over he set them out. He protected and nursed them along with surprising success, for in the constant warm sunlight they grew fast and many managed to bloom. He was greatly disappointed, however, in his sunflowers. They grew tall and strong, and developed splendid big buds, but as fast as they blossomed they developed weak stems! For, as the blossoms followed the sun around during the 24-hour days, they wrung their own necks!

April, 1944

Portland, Oregon

STATE DEPARTMENT OF GEOLOGY & MINERAL INDUSTRIES
Head Office: 702 Woodlark Bldg., Portland, Oregon

State Governing Board

W. H. Strayer, Chairman Baker
Niel R. Allen Grants Pass
S. H. Williston Portland

Earl K. Nixon Director
F. W. Libbey Mining Engineer
John Elliot Allen Geologist
H. C. Harrison Chief Chemist

State Assay Laboratories

714 E. H Street, Grants Pass
W. A. G. Bennett Field Geologist

2102 Court Street, Baker
Norman S. Wagner Field Geologist

DON'T YOU BELIEVE IT!

Introductory

Statements, supposed to be based on a comprehensive knowledge of the mining industry, issue from non-technical official Washington sources from time to time. One such statement was in substance that mining has lost much of its element of risk and has evolved into large scale operations comparable with large manufacturing projects. This was especially enlightening to miners in the West. Now Mr. William L. Batt, Vice-Chairman of the War Production Board, is reported to have stated in a public address that many of our natural resources are approaching exhaustion - that in the field of minerals and metals after the war we shall be a "have not" nation. In his address he advocated that stockpiles of critical minerals be accumulated from imports and that our own dwindling mineral supplies be used as sparingly as possible so that they would be available for use in a possible future emergency.

If such statements did not represent the thought of leaders who shape our policies, they could be dismissed as made by persons unfamiliar with the technical side of mining, but the implications contained in the statements made by Mr. Batt are especially dangerous to the maintenance of a healthy domestic mining industry. Such statements should be carefully and fully examined.

To people unfamiliar with the mining industry, Mr. Batt's ideas sound plausible. If we are using mineral supplies at an unprecedented rate, and this is true, then the apparently logical conclusion is that the remaining reserves should be preserved in the interest of national safety. However, there are two principal fallacies involved. They are the dogmatic assumptions, first, that our known reserves have been dangerously depleted, and second, that these known reserves represent the limit of our mineral resources.

Let us examine the record of allegedly depleted reserves of metals in order to weigh these assumptions.

Domestic Mineral Reserves

Tin: The United States always was a "have not" nation insofar as known reserves of tin are concerned. If the pre-war recommendations of many informed individuals and groups concerning stockpiles had been acted upon by those in authority, the severe shortage of tin supplies would not have developed. Adequate stockpiles of tin should be maintained after the war and of course they must represent imports.

Nickel: Many of the same conditions exist with regard to nickel. A very important difference between tin and nickel supplies, however, is that the principal source of nickel is in Canada, and delivery of this important metal is not dependent on ocean transportation. Presumably this source of supply would be available to us in a future emergency. Nevertheless, in the interest of national security, nickel should be stockpiled and as large a proportion as possible should be utilized from the production of an American-owned operation in Cuba.

Chromite: As for chromite, large reserves of low-grade chrome have been developed in this country, and post-war reserves will be much greater in the aggregate than those known before the war. Adequate reserves of metallurgical grade ore have always been lacking. Utilization of this low-grade chromite is a metallurgical and economic problem; at present there is no question of depletion of reserves. Processes for producing a metallurgical grade product from our low-grade ore have been worked out in detail. At the beginning of the war when our supplies of chrome were dangerously low and submarine sinkings were alarming, the War Production Board made strenuous efforts to get all our low-grade deposits into production. They wanted all the domestic chrome they could get and were not very critical of the grade. Of course there was a large time lag and, before the low-grade could be utilized, imports relieved the shortage. The plants to treat low-grade were then closed. In the interest of national security the low-grade should be treated on a commercial scale to produce an acceptable metallurgical product so that we should not be so dependent on foreign ores.

Manganese: Before the war our metallurgical manganese ore supplies were mainly obtained from foreign countries. The war has greatly stimulated production so that our domestic output, principally from Montana, fills a material part of our requirements. It is reported that the production from Montana and that from Cuba would supply from a third to a half of our peacetime needs. A large plant producing manganese oxide from low-grade ore is now in operation in Nevada. Large reserves of low-grade ore, some of them partially developed, are known to occur in the West. While part of our post-war requirements will necessarily be imported, our domestic industry is fully able to supply a larger proportion of our domestic demand than ever before.

Vanadium: Domestic vanadium reserves have been greatly increased during the war period. Aside from the deposits of vanadium ore in the West, large reserves of vanadium-bearing titaniferous magnetites have been developed - principally as iron ores. Processes have been perfected for the extraction of vanadium from these ores.

Molybdenum: The United States possesses by far the largest known reserves of molybdenum. In addition to the large quantity developed at the Climax property in Colorado, the large porphyry copper mines now produce a very material amount of molybdenite as a by-product of copper operations. A shortage of molybdenum is not discernible at the present time. If we were to import molybdenum ore where should we look for a foreign supply?

Mercury: As for mercury, domestic conditions are clear-cut. Production in this branch of metal mining reflects price changes more quickly than in any other. Under the price incentive, beginning in 1939, and spurred by national need as well as urgings of the War Production Board, the industry increased production enough to meet all needs. Several important new discoveries have been made as a result of intensive exploration, and the known reserves now are greater than before the war. Our large production, augmented by imports, has resulted in a large stockpile accumulation, and the domestic price has dropped sharply. Domestic production is therefore falling off. If because of low price the domestic industry sinks again into relative obscurity, as now seems likely, it would require considerable time to raise production sufficiently to meet another war emergency.

Tungsten: This country was short of tungsten when the war began as we had been mainly dependent on imports. Adequate stockpiles had not been accumulated. Under the stimulus of price as well as need, production increased and new deposits were developed so that we have been able to meet war needs. This procedure was time-consuming as it would always be with this or any other like mineral. Known domestic reserves of tungsten are greater now than ever before.

Antimony: Antimony supplies were in much the same category as tungsten when we entered the war. Most of our antimony had come from China. When these supplies were cut off, we were finally able to produce a large part of our needs through increased capacity of smelters treating antimonial lead ores, together with production from the Stibnite mine in the Yellow Pine district, and the increased output from new facilities in the Coeur d'Alene, both in Idaho. Increased imports from Mexico also added to supplies until at the present time there is no shortage of antimony. Certainly our antimony reserves have not been depleted.

Aluminum: Concerning aluminum, it is common knowledge that present reduction methods require high-grade bauxite and that domestic reserves of this grade - never very large - have been largely depleted. Large reserves of high-grade bauxite are known in the Guianas and these sources are being drawn upon. For reasons peculiar to the aluminum industry, these imports will continue after the war. The domestic industry is thus dependent on material subject to the war hazards of ocean transportation while large reserves of low-grade bauxite and very extensive reserves of high alumina clay are known in this country. Testing work to develop commercial processes for production of alumina from these lower grade materials is being conducted by private groups and by the U.S. Bureau of Mines. It seems obvious that national security demands that this testing work should receive national support. The technical problem concerned with utilization of the low-grade materials is primarily an economic one. Interest in its solution should not lapse because the immediate need for domestic sources of alumina has lessened.

Magnesium: Pre-war production of magnesium had been relatively small. Increased use of light metal alloys, occasioned by the war, multiplied the demand for magnesium many times. Fortunately for the country, the Dow Chemical Company had previously worked out plans for producing magnesium from sea water on the Gulf Coast. The facilities designed by this company were expanded without difficulty and thus the shortage of magnesium did not become serious. In addition, other processes, some not well developed, were applied and plants to use them were built. Raw materials for these plants are dolomite, brucite, and magnesite. Some of this production is costly, but at the present time it is reported that magnesium is being produced in excess of all our needs. This is an illustration of what American metallurgists and engineers can do, given time. Certainly no one who is informed can assert that domestic raw materials needed for the production of magnesium have been depleted.

Copper, Lead, Zinc: For the purposes of this discussion, copper, lead, and zinc fall in the same classification. Undoubtedly, serious inroads have been made in known domestic reserves of these metals. It is believed by the writer that a major mistake in policy was made early in the emergency period in fixing the ceiling prices of these metals, particularly copper. This policy was an effective barrier to expansion, not only in the search for new deposits but also in the utilization of marginal ore bodies. Later on, the price restrictions were grudgingly liberalized somewhat but the strings attached to the bonus prices allowed were strict enough so that nothing in the way of substantial new prospecting or the opening of new mines resulted. Thus depletion of known reserves was the inevitable result. After the war, removal of Governmental domination together with a less oppressive tax policy would put new life into the industry and would certainly result in new discoveries of copper, lead, and zinc deposits. There should be sufficient incentive to operators so that they may be encouraged not only to produce from domestic properties but also to engage actively in exploration. From evidence at hand, it appears that known world reserves of zinc are not large. The long range future for zinc is uncertain, but we should have a domestic price sufficient to encourage exploration.

Iron: Because of the huge demands of a highly industrialized nation for steel, iron ore needs stand out in national importance. Even before the war, the end of the easily mined high-grade Minnesota ores was in sight. The war has speeded up the depleting process. This does not mean, however, that the iron ore resources of this nation are approaching exhaustion. It does mean that we must soon turn to sources other than the soft ores of the Lake Superior region in order to supply our steel industry with a large part of its

requirements. These new sources are known and are very extensive. In general, it means a somewhat increased cost of ore and some metallurgical problems which are being worked out. It means also greater use of western iron ores. It seems likely that imports of iron ore from South America will increase over a period of years, but placing emphasis on need for importing large quantities of South American iron ores, for instance from Brazil, would result in weakening our iron mining industry, the backbone of our industrial progress.

Comments and Conclusions

It is clearly evident that our mineral resources are not in the depleted condition indicated by Mr. Batt. Some of our metallic ores have greater known resources than ever before. Known reserves of copper, lead, and zinc ores have been heavily drawn upon. National policies have been largely responsible for failure to develop new reserves to replace those mined out, but this condition could be corrected. Iron ore resources are still huge even if the end of the "soft ores" is in sight.

In analyzing Mr. Batt's ideas, some rather tough questions for him to answer bob up. He says that we should "use as little as possible of our own precious remaining supplies." They are not supplies unless they are either mined and lie on top of the ground or are developed underground. In either instance the expense of maintaining these supplies for a future emergency would be altogether too great for a private operator. If these mineral supplies are not developed their existence is not proved and therefore they are not supplies. Apparently, Mr. Batt believes that our mineral resources are all known; therefore they must be at least partially developed. If they are not known, how can Mr. Batt be sure they are approaching exhaustion?

It should be pointed out that one important factor in the depletion of domestic ore reserves in underground mines is the continued lack of mine manpower. In the majority of mines, it has been necessary to cut down development work because of this lack of miners. It is a truism to state that failure to do development work in a mining operation results in early exhaustion of ore reserves. Even if evidence exists that ore would be found if exploration were carried out, the ore is not available until it has been developed.

Another basic fact concerning the ability of the mining industry to meet an emergency, and one which quite evidently is not given sufficient weight by those not experienced in mining, is that an ore deposit may not be put into condition to produce simply by putting up a plant at the will of Government officials. Time-consuming development work must follow discovery. This development work is essential not only to determine the extent of the deposit but also to enable the operator to select the proper method of mining and the most economical method of treatment. The development program would always be especially time-consuming under war conditions because of difficulties in obtaining equipment and capable manpower.

No factor in industry prevents earnest application to the job at hand so much as uncertainty about policies from higher up. This matter is especially pertinent in planning post-war readjustment, and the uncertainty of Government action relative to post-war primary and secondary metal surpluses is a striking example. Mine operators have had to keep one ear - sometimes both - cocked continually toward Washington in order to keep abreast of regulations and policies. The job of developing, mining, and smelting to meet war demands has been an especially tough one - and a seemingly thankless one. A magnificent job, in spite of great difficulties, has been and is being done. Along these lines, members of Congress realize the failings of the present piece-meal tax policies and undoubtedly will make a determined effort to effect remedies. A settled tax policy would allow operators to plan ahead with some assurance that new taxes levied a year or so ahead will not kill any chance of making a profit. This uncertainty in itself is a great barrier to development of new ore deposits. As a matter of cold, hard fact, present mine taxation policies have prevented, are preventing, and will continue to prevent the starting of new mining projects.

In connection with some Government policies relating to production of war minerals, the experience of many mine operators, especially the smaller ones, has been disillusioning. These operators were eager from patriotic motives to find and produce needed minerals. Early in the emergency they were urged by Government agencies to get into maximum production as quickly as possible. When the critical need for domestic production had passed because of increase in imports, the small operator who had sweated to get into production became "the forgotten man" as far as these agencies were concerned. He was made to feel that his efforts were of no importance. If he lost money in his project, that was his hard luck. In general this type of man finds our mines. The result of his discouragement is that there is little or no prospecting going on; known mineral prospects are lying dormant. In addition he will examine any possible future emergency needs with a cynical and jaundiced eye.

"Trial balloons" are fairly common in official Government quarters. Sometimes they are meant to try out public opinion and sometimes they are designed to pave the way to a definitely planned national policy. * Aside from "Lend Lease" commitments which probably must be written off, post-war foreign trade will consist largely of exchange of some of our manufactured goods for raw materials, as this will be the only method available to some countries of making payment. Possibly, as hinted in Mr. Batt's remarks, plans are being made to import as large a proportion of mineral products as possible. Some of our large corporations would be in full accord with this policy. The menace to the domestic mining industry is apparent. Our international outlook as, for example, the "Good Neighbor" policy is fine if it does not include crucifying a domestic industry which is the basis of our industrial leadership. Other countries are going to approach such post-war problems primarily from a selfish standpoint. We must be equally realistic.

We shall of course import mineral raw materials as we have done in the past peacetime era, but if there is an expansion in these imports it will be the result of a foreign trade policy set up at the expense of our mineral industry. It will not be due to depletion of our mineral resources. America can only be made a "have not" nation by inept political planning.

Probably Mr. Batt's statements were based on information furnished him from sources which he considered reliable, but in any event this is an example of official or semi-official statement not based on sound technical advice. Such statements are likely to contain inaccuracies. The far-reaching danger is that they are accepted as 100 percent accurate by people unfamiliar with the technical details.

F.W. Libbey.

COMING COAL ERA*

(An Abstract)

Of all the fuels available for use in the future, coal will be of paramount importance. Even the coal industry's severest competitors admit this. The future is an indefinite term, but the time that coal will assume undeniable superiority will depend largely if not entirely on two factors: The overall economic status of this country, and the extent to which the coal industry is willing to exert itself in order to secure the markets which will exist.

Using indices of business trends during other post-war periods as a guide, it has been predicted by the Bureau of Foreign and Domestic Commerce that the national income will show a steady increase during the years immediately following the war. A decline from this post-war "boom" will probably develop after a few years but the average income level has been higher and higher after each war. Coal consumption follows general business trends closely while railroad traffic and pig iron production, both heavy coal consumers, directly reflect general business conditions. Railroad men expect an upward trend in passenger and freight ton miles in the post-war era, and the forecast for pig iron production is for continued gains, although not at the peak levels of today.

* From "Coal Age" March, 1944

Bright though the future may be for coal, no substantial gains can be or will be made by merely sitting back and waiting for business to come. By dint of unceasing exploitation and promotion during the past two decades, oil has become coal's toughest competitor. Natural gas, too, is a bothersome rival but it lacks the geographical flexibility enjoyed by coal. The future of water power as a competitor of coal is dependent partly on political trends and partly on economic factors. Barring some local exceptions, coal has ably demonstrated that on an economy basis it can compete with water power.

Despite the fact that, in the United States, the reserves of crude oil are limited, this does not mean that oil has yielded to the greater reserves of coal. On the contrary, oil men in this country are looking to foreign sources to carry on. They also hope that there will be a price increase to permit further wild-cattling in this country. Assuming then that oil will be a doughty rival of coal for at least some years to come, what are the factors in favor of coal over oil? A public sufficiently convinced that there is an impending oil shortage will be wary of investing in oil burning equipment, and national security will most certainly require that restrictions be placed on crude oil consumption in order to preserve stocks for future emergencies. Both of these facts tend to move home heating, steam and industrial markets into coal's hands. Oil has one big advantage in convenience, and one of coal's biggest jobs is to supply a product more acceptable to the consumer.

In the opinion of experts the greatest opportunities for coal lie not in brand new, heretofore unheard-of fields, but in markets already well established.

The major markets for coal together with prospects for future demands are tabulated below.

THE FUTURE FOR COAL IN PRINCIPAL MARKETS

<u>Markets</u>	<u>Future Trends</u>	<u>Research and Improvements Needed</u>
Electric Power Gas Production	Greatly expanded use. Gasification to take large tonnage.	Improved firing equipment and coal research on low cost gasification.
Liquid Fuels	Rapidly increasing in importance.	Additional commercial research and testing.
By-products	Increased use as a fuel. Minor use as raw material.	Better preparation. Research on raw material uses.
Heating	Increased use but with strong competition.	Better preparation; better equipment.
Industrial	Increased use with new applications.	Better preparation; better equipment; new uses.
Colloidal Fuels	Probably increased marine use only.	Cost reduction; product improvement.
Railways	Increased traffic but competition with diesel and electricity strong.	New boiler design; better preparation.

In the electric power and gas production field of the future, coal will enjoy a favored position. Utilities are demanding a more uniform coal, better prepared, and stoker equipment capable of disposing of ashes automatically. These problems are being met now and should be solved in due course. Of equal importance is the future manufactured-gas market. Both coal and gas made from coal compete in the same market. Gas produced from coal is a fuel

having none of the disagreeable qualities of coal, such as ash disposal, shoveling regulation, shaking, and attention. Liquid fuels for internal combustion motors is another likely possibility, which will become increasingly important as crude oil stocks diminish. Production of both gas and liquid fuels from coal yields coke as a by-product which in itself competes directly with gas. Complete one-step gasification of coal would remedy this.

In the chemical and plastics field, coal will play its most important role as a source of energy rather than as a raw product. Expansion in this industry is inevitable with coal keeping pace and probably gaining in use over oil and grain alcohols.

Domestic and space heating annually consume over 100,000,000 tons of coal - the "cream of the crop" for bituminous, while such use is the principal outlet for anthracite. Oil has given coal a stiff fight for supremacy in the heating field, although coal, aided by the benefits from continual research, has slowly been improving its position. A combination heating and cooling unit for domestic use is being studied and if successful would result in a substantial tonnage increase. "Customer satisfaction" is the main theme of all coal research today. Studies now under way are aimed at better control of heating units, interval without attention, less manual control, and the supply of better coal at a cost below that of oil. Laboratory officials are hopeful of developing a domestic stoker which will be entirely automatic and yet medium priced. Smoke abatement receives increasingly greater attention as more and more cities clamp down on smoke tolerances. Ready for use in the post-war period is a completely smokeless stove which can be banked for as long as 4 days and still heat quickly upon opening the draft. Powdered, liquid, or gaseous fuel derived from coal for domestic use are all definite possibilities, with increased convenience at a cost still below competing fuels.

Industrial users of coal for heating and steam production are primarily concerned with the cost per heat unit. Coal has a decided advantage in this respect which, coupled with an assured supply, makes it doubly attractive to large industrial users. Battelle Memorial Institute which does much work for the Bituminous Coal Research program believes that pulverized coal will be the fuel of the future. Use of this type of fuel in radiant tube boilers is receiving considerable attention.

One of the most interesting uses for coal industrially is not for steam use but in open hearth steel furnaces. This use could amount to as much as 20,000,000 tons a year although several serious engineering obstacles must be overcome.

Colloidal fuel has been the subject of much discussion but production has been very limited. Future use would be confined largely to marine service where its greater heat per unit permits a saving in storage space. High production costs at present bar it from railroad markets and will probably continue to do so.

Torn between increased rail traffic and a growing use of diesel-powered units, coal faces an uncertain future. Railroads burned 110,000,000 tons of coal in 1942, thus becoming the largest individual customer of the industry. Oil as a competitive locomotive fuel will in all likelihood not change its relative position, being largely determined by local supply. Diesel offers more widespread competition, but entirely new boiler design for coal burning locomotives can improve coal's position. The present steam locomotive has an almost complete lack of efficiency, differing so little from the original as designed by George Stephenson that he would have little difficulty in recognizing the most modern steam locomotive as being basically his design. Water-tube boilers with turbo-electric drives are the hope of researchers, rather than improvement of present models. Coal as a locomotive fuel would be very difficult to replace if its overall efficiency could be increased by 50 percent or even 100 percent, giving drawbar efficiencies of from $7\frac{1}{2}$ percent to 10 percent. A comparison of diesel and coal-fired steam locomotive costs per mile for a 6 months' period on the Santa Fe line is interesting. While steam locomotives cost 68¢ a mile to operate, diesel engines cost 81¢; fuel costs were slightly higher for steam, but depreciation and repair costs for diesel units amounted to 40¢ to steam's 30¢.

The 1943 production of bituminous coal was 589,000,000 tons, with anthracite totaling 61,000,000. This year it is expected that 620,000,000 tons of bituminous and 65,000,000 tons of anthracite will be produced. There is every indication that there will be ever expanding markets for coal but they will not be won without a fight led by research groups and backed by the entire industry.

EARL K. NIXON JOINS FREEPORT SULPHUR COMPANY
AS MANAGER OF WESTERN EXPLORATION

Earl Nixon has resigned as director of the State Department of Geology and Mineral Industries to accept the position of Manager of Western Exploration for the Freeport Sulphur Company. His headquarters will be in San Francisco in order to afford a central location for the company's program of mineral and industrial investigations in the western states, western Canada, and Alaska.

Mr. Nixon was appointed the first director of the newly formed department in 1937 by the first Governing Board then composed of Senator W. H. Strayer, Mr. E. B. McNaughton, and the late Mr. Albert Burch. He organized the department, selected its personnel, and planned its projects. He had the foresight to see the need for strategic mineral development and, in addition to many other mineral industry studies, had surveys made of the State's resources of quicksilver, chromite, and manganese so that reports of these important war minerals were available when the war emergency came. Largely through his efforts three Metals Reserve Company purchasing depots were established in the State. He became consultant for the War Production Board and the Metal Reserves Company and was appointed State Emergency Coordinator of Mines by Governor Sprague.

Because of Mr. Nixon's efforts, the Oregon department has attained a prominent place among state mineral industry departments, and a few months ago he was elected president of the Association of American State Geologists. What the department has accomplished is in great measure due to his energy and ability. He will be greatly missed by his associates in the Department. Their sincere good wishes for his success go with him in his new work.

CRITICAL MATERIALS

According to the American Mining Congress Weekly Information Service, issue of April 15, WPB's latest (April 15) list showing "degree of criticalness" of various raw materials is substantially as follows:

"The only metals now listed in Group I (materials insufficient to satisfy war plus essential industry demands) are cadmium, sodium, tin, columbium, nickel, and malleable iron castings. Bismuth, platinum and tantalum have been moved down into Group II (materials sufficient to meet war plus essential industry demands), which Group also contains aluminum, beryllium, copper, lead, magnesium, silver, zinc and steel. Low carbon ferrochromium has been moved up into Group II from Group III. Group III (materials readily available for essential uses) includes antimony, calcium, gold, mercury, palladium, cobalt, molybdenum, most of the ferro-alloys, pig iron, grey iron castings, reinforcing, and rerolled rail.

"Among the chemicals listed, arsenic and its derivatives, calcium carbide, lithium chemicals, sulfuric acid, and superphosphates have been moved from Group I down to Group II; strontium chemicals from Group II to Group III.

"Most grades of lumber continue critical, with only minor changes in classification. Of the "Miscellaneous Products", barite and anthracite coal have become more critical and have been shifted from Group II to Group I, and long fibre asbestos from Group III to Group I. Low silica bauxite and fluorspar (both acid and metallurgical grades), together with second and third qualities of quartz crystals, have been eased from Group I to Group II. Lead pigments, salt, and stone, previously listed in Group III, do not appear in the latest list."

STATE DEPARTMENT OF GEOLOGY & MINERAL INDUSTRIES
Head Office: 702 Woodlark Bldg., Portland, Oregon

State Governing Board

W. H. Strayer, Chairman Baker
Niel R. Allen Grants Pass
S. H. Williston Portland

F. W. Libbey Acting Director
John Eliot Allen Geologist
Esther W. Miller Ceramic Engineer

State Field Offices

714 E. H Street, Grants Pass
W. A. G. Bennett Field Geologist

2102 Court Street, Baker
Norman S. Wagner Field Geologist

MICROCHEMISTRY IN RESEARCH AND INDUSTRY*

by

H. C. Harrison

Analytical chemistry is probably the most fundamental branch of chemistry. Before work involving inorganic, physical, organic, physiological or any other branch of chemistry can be carried on, it is essential that the composition of the materials used be known. The only way to obtain this information is by analysis, yet until about twenty years ago developments in analytical techniques and procedures had been woefully neglected. During the 75 preceding years, methods of qualitative and quantitative analysis had not kept up with advancements in other fields of science. During this period many of the basic instruments now widely used in analytical chemistry had been fairly well developed, yet little attempt had been made to apply them to analytical problems. It is true that research in this field is much less spectacular than that in many other branches of chemistry, and the general attitude appeared to be that analytical procedures had been worked out for the most common substances, and even though most of these methods were time-consuming this unfortunate feature was just something to be endured.

There is no authentic record of the development of the first balance, yet we know that a balance was used by Archimedes in 280 B.C. when he performed what was probably the first recorded quantitative experiment. In an attempt to discover whether air had weight, he placed an inflated bladder on the balance and then deflated the bladder. As he found no difference in weight after deflation, he concluded that air had no weight.

Janssen invented the first microscope in 1590. In 1678 Hooke published Micrographia, the first book on microscopy, yet the microscope did not take its place as an indispensable analytical tool until the early 1900's, and it is of interest to note that C. W. Mason, a graduate of the chemistry department of the University of Oregon, played an extremely important part in the development of modern chemical microscopy.

Newton performed his historic experiments on the nature of light in 1666 and in doing so actually developed the fundamentals of spectrochemical analysis. In 1758 Andreas Sigmund Morggrof, a pioneer analytical chemist, showed that sodium and potassium could be distinguished in a flame. In the late 1700's and early 1800's discoveries were made which have proved to be of extreme importance in present day chemistry. Herschel discovered the infra-red region of the spectrum in 1800. Ritter discovered the ultra-violet region in 1801. Davy developed the method of electrolytic deposition in 1806. It was during this period that Berzelius, undoubtedly one of the greatest of all analytical chemists, was doing much of the research which proved to be the ground work for analytical chemistry up to the present time.

* From a talk given by Dr. Harrison, chief chemist and spectroscopist of the Department of Geology and Mineral Industries, to the Department of Chemistry, University of Oregon, April 25, 1944.

Working in a laboratory set up in two ordinary rooms without furnaces, hoods, gas, or water, and with a sink consisting of a stone water-holder with a stopcock and a pot standing under it, this chemist analyzed more than two thousand chemical substances, and determined the atomic weight of fifty different elements with remarkable accuracy. The scheme of blowpipe analysis devised by Berzelius is very similar to the one in use at the present time, and a large number of his quantitative procedures form the basis of present day quantitative techniques.

In 1859 Bunsen and Kirchoff built the first modern spectroscope and with its aid discovered the elements rubidium and cesium. One of the types of spectroscopes in use at the present time is almost identical with the one built by Bunsen and Kirchoff. These two men studied the spectra of a number of elements and laid the groundwork for the science of spectrochemical analysis. By 1864 the knowledge of how to produce spectra of a number of metals was available, and the elements rubidium, cesium, indium, and thallium had been discovered with the aid of the spectroscope. However, the original expectation that this method of analysis would find widespread use did not materialize, and even today the majority of chemistry students are not instructed in chemical spectroscopy. There are a number of reasons why this method has been neglected, among which might be listed the fact that its extreme sensitivity frequently causes confusion in the mind of the inexperienced worker. The flame method of spectral excitation is limited in usefulness and it was not until arc and spark sources were developed that full advantage could be taken of the spectroscope. When the arc or spark was used many elements gave spectra which were very rich in lines and, until wavelength tables had been compiled, it was frequently easier to make a routine chemical analysis than to interpret the spectra. Widespread application of the spectrograph was retarded also until photography could be applied. Fifty years ago photography was not well developed and this is the only way of satisfactorily recording the ultraviolet region of the spectrum; it is in this portion of the spectrum that most spectrographic investigation is carried out. The science of spectroscopy did not progress to any extent after Bunsen's death until the medium size quartz spectrograph was developed in 1909 and the large quartz spectrograph was developed in 1912. The modern reflection grating spectrograph is a relatively recent development which was not made efficient until the method of sputtering or evaporating aluminum on glass had been developed. Previously reflection gratings were made of speculum metal and only a very small proportion of the light was reflected and made available for analysis with the result that sensitivity of the spectrographic method was very low. Today spectrochemical analysis is almost indispensable in the metallurgical industry and is widely used in many fields of chemistry.

In the early part of the 1900's, analytical chemistry began to emerge from the doldrums, and we are now in a period of intense interest in the development of analytical methods and instruments for doing analyses in hours or minutes, which previously had required days, weeks, and even months. The modern analytical chemist can no longer confine his activities to "wet work" using time-proved methods involving little more than weighing, precipitating, titrating, drying, and re-weighing. Instead he must be a combination of research chemist, expert machinist, radio technician, electrical engineer, and optical physicist. He must know something about emission and absorption of light, recording and non-recording mechanisms, and photography; he must have an understanding of vacuum tubes and amplifying systems and must be able to apply all of these diverse phases of knowledge to the repair, maintenance, and development of his apparatus.

During World War I when our supply of dyes from Germany was cut off, organic chemists in the United States were vitally interested in the synthesis of organic compounds, particularly those types which would replace or become substitutes for dyes. This type of development was extremely fortunate for analytical chemistry because, in determining the properties of these thousands of newly synthesized organic compounds, it was discovered that a number of them were specific reagents¹ for qualitative identification of ions, and

1. Specific reagent is a reagent which gives a characteristic reaction with one and only one ion.

in fact some of them were of sufficient value to indicate their use as new qualitative precipitating agents or as indicators in volumetric titrations. Organic reagents for qualitative analysis were not entirely new at this time as they had been used as indicators for determining pH values, and for some time dimethylglyoxime had been used for the determination of nickel.

A number of Austrian chemists, among whom should be listed Pregl, Emich, and Feigl, developed a field of chemistry which is very much in use at the present time. Pregl developed, mainly in the field of organic chemistry, a great number of methods of analysis whereby it is possible to make extremely accurate quantitative analyses using samples weighing from 3 to 5 milligrams (about one hundredth of the quantity used in macro², or large scale, analysis). Much of his apparatus consists of cleverly modified forms of similar macro-equipment and the use of this type of apparatus caught the fancy of many chemists. These Austrian chemists were working along the line of microchemistry³ as early as 1918 - a time when there was intense activity along the lines of organic chemistry. As Professor of Analytical Chemistry at the University of Vienna, Dr. Fritz Feigl conceived a logical version of microtechnique whereby optical instruments were not required. His procedure involved the use of large-sized drops of solutions and this led to the terminology of "spot analysis" for his system. Feigl worked systematically in the whole field of analytical chemistry. He carried on extensive research programs and with the help of his students supplied the German chemical journals with information concerning Spot Tests by Feigl and his workers.

Feigl condensed all of his literature and personal experiences into a comprehensive book which was published in German in April 1931. In spite of its importance it did not receive proper recognition in this country until it was published in English in 1937 under the title of Spot Tests. The textbook Elementary Chemical Microscopy, written in 1914, was revised and published under the title of Handbooks of Chemical Microscopy by Chamot and Mason, and these books did much to awaken interest in the use of the microscope in chemical analysis and in the identification of a number of different kinds of substances such as hairs, fibers, different kinds of paper, etc.

With the advent of spot tests, chemical microscopy, organic microanalysis as taught by Pregl, the use of organic reagents as specifics, and the renewed interest in spectroscopy, analytical chemistry as a science received what is frequently referred to in the vernacular as a "shot in the arm." Chemists who had been accustomed to analytical methods handed down for almost fifty years were suddenly confronted with a maze of new chemical techniques, most of which had not undergone the test of time. In fact some extremely promising techniques such as Professor Heyrovsky's method of analysis using the polarized dropping-mercury-electrode were not given the immediate attention that they deserved.

Some of the confusion which occurred in the early and middle 1930's was undoubtedly due to the fact that enthusiasts for each of these new methods made extravagant claims, and it was only after each of the methods had been thoroughly tried out that it was learned that none of these methods would replace all other analytical methods. It was found that each had a definite value and when used to supplement each other they allowed the chemist to attack many problems which twenty-five years ago seemed insurmountable.

It is now agreed that procedures using microtechniques have their place along with macromethods. They have definite advantages over macromethods but they also have their limitations, and when these limitations are understood and taken into consideration it is frequently found that microtechniques will advantageously replace a number of techniques employing macromethods.

-
2. Macroanalysis is performed on a relatively large scale as compared to microanalysis.
 3. Microanalysis is performed on minute amounts of material usually requiring very sensitive or small-scale apparatus.

When we think of microanalysis our main thought concerns the advantage of being able to achieve the desired results with only a small quantity of sample, and in many instances this is the primary consideration in choosing a micromethod over a macromethod. However it is important to remember that the time element should also be taken into consideration in choosing a method. In industry, time is money and a chemist working for an industrial concern is usually under constant pressure to complete his analyses as rapidly as possible. Micromethods tend to employ a greater number of specific tests than do comparable macromethods, and this frequently means that numerous short cuts can be taken in most routine procedures. From the standpoint of the teacher, the consensus is that students are more keenly interested in those procedures which employ micromethods and apparatus. A group of students using micro- or semi-micromethods can be expected to complete more work in unit time and with more accurate results than a similar group using macromethods.

Unfortunately all micromethods are subject to a common error which might well lead to erroneous analytical results if the analyst does not take suitable precautions. This is often referred to as the sampling error. No analysis, no matter how carefully performed, should be reported to a greater degree of accuracy than that of the method used in obtaining the sample. The sampling error is a nightmare to all analytical chemists but is particularly serious whenever micromethods are used. Micromethods employ a much smaller sample than macromethods and therefore extreme care must be taken to be certain that the sample used in the analysis is truly representative of the bulk of the material being analyzed. There are a number of precautions that can be taken in obtaining a representative sample, but in many cases such precautions require so much time or trouble that it might be better to make the analysis using macroprocedures. In some instances, particularly when the microtechnique is being used on solutions, it is possible to put a large amount of material into solution and make the analysis on an aliquot portion. Each sampling problem should be carefully considered in the light of the method of analysis to be used if micromethods are to yield reliable results. Unfortunately the general public does not have an understanding of the sampling problem. The analyst frequently receives a piece of rock about the size of a robin's egg accompanied by a request that it be analyzed for certain elements. The analysis is made and it is later learned that the analytical results are taken as proving that the whole mountain from which the rock was taken has the identical composition as that of the rock submitted for analysis. Another problem frequently encountered by analysts is that of receiving a sample too small even for micromethods. It is not uncommon for someone to send in a fifty to one hundred pound sample for spectrographic analysis. This is not a serious problem as the sample can be split down and a truly representative sample obtained. If the sender comes to the laboratory to discuss the results of the analysis he frequently asks how much of the sample was used for analysis and, upon learning that about 100 mgs was used, he remembers how much it cost him to send the original sample and the next time he submits a sample which is too small to be truly representative or even too small to make check analyses. One spectrographic laboratory in the East has established the policy of requiring the sender to put small samples in the electrodes to be used in the analysis so that all of the responsibility for possible loss of the sample will be assumed by the sender.

Let us review rapidly some of the different branches of microchemistry and see if we can evaluate these methods with regard to their use in research and industry.

1. Micro-organic analysis as introduced by Pregl and later improved upon by numerous other workers: This type of analysis has proved to be indispensable to the research chemist working in the field of organic chemistry. It affords the only rapid method of obtaining an ultimate quantitative analysis of an organic compound, and also enables one to obtain the quantitative analysis of organic compounds for a large number of different organic radicals. In the field of synthesis of new organic compounds it is essential that the composition and a number of physical properties be determined before the identity of a new compound is established. There have been any number of instances in which an organic

chemist has spent a year or more synthesizing or isolating an organic compound, and the fruit of his labors consisted of not more than a few hundred milligrams of the organic compound. He usually must determine percentage of carbon and hydrogen, and in addition must know the melting point or boiling point, and the percentage of a number of other elements such as nitrogen, phosphorus, halogens, and sulfur. The size of his sample makes it imperative that micromethods be used. In routine organic analysis, semi-micromethods for organic combustion, nitrogen, and a number of other determinations are now widely used.

2. Chemical microscopy includes a number of different types of analytical procedures. Most of these procedures are qualitative in nature, and the majority of tests for anions and cations involve ionic reactions quite similar to those used in both micro and macro qualitative analysis. It is usually necessary to make a number of group separations and to detect the sought-for ion by means of a color reaction or by converting it into a crystal form which is characteristic and easily identifiable. Identifying tests have been established for nearly all of the known metals as well as most of the inorganic and some of the organic anions, and therefore it is much more versatile than most macro or micro qualitative procedures which usually include only about thirty odd cation identifications and a few anion identifications. In addition to routine qualitative ion determination, chemical microscopy has the great advantage of employing the optical properties of crystals as a means of identification, and by this means it is possible to differentiate between chemical compounds which have identical or nearly identical chemical composition yet differ greatly in optical properties.

Another type of microanalysis employing the microscope as the main tool is petrography. This type of analysis is of extreme importance in certain fields of science particularly in geology and mineralogy. The technique varies according to the type of work being done but in general petrographers who work on rocks and minerals prefer the thin-section technique while those working on industrial problems make more use of the oil-immersion method. In the thin-section method the material to be studied is cut in a thin slice and then ground on a special type of grinding wheel until the rock section is transparent to light. Using this technique the material under investigation is studied in about the same form as it originally existed, while if the powdered method is used the sample is crushed to a powder and thus the original structure is destroyed. Both types of technique have their place and a petrographer should be equally familiar with each. The main advantage of petrography seems to lie in the fact that the compounds in their original material can be identified and this is impossible when methods are used which require that the sample be put into solution to obtain ions, or when the physical character of the sample is altered. The main disadvantage of petrography is that opaque substances are not susceptible to this type of analysis except by using reflected light from the surface of polished sections and these techniques are not as well developed as in the thin-section and oil-immersion methods.

One of the outstanding spectroscopists, working in the field of rocks, ores, and minerals, has said that the real secret of his success rested in great part on the fact that he was working in the same laboratory with a good petrographer. Petrography and spectrography supplement each other in this type of work and whenever possible should be used jointly on an investigation.

3. X-ray analysis plays its own part as a valuable tool in the hands of the scientists. It is used in metal testing, as an important asset to research laboratories; it is almost essential in certain types of mineral identification, and in numerous other applications. Until a few years ago X-ray analysis was rather limited by the fact that very few tables of fundamental figures and patterns had been published. Each worker had to work out his own salvation and thus much fundamental work was repeated by a number of scientists. About 1936-1937 an extremely important list of these data was published in a special edition of the American Chemical Society, and this list has greatly stimulated

work in this field. It is to be expected that interest in X-ray methods will continue to grow, and it is safe to predict that within a relatively few years most universities will offer some type of course in this field.

4. The use of the electron microscope is a relatively recent development. In 1937 Dr. Louis Caryl Graton, a Harvard professor, announced a new microscope weighing about one ton, which with utmost precision, using a range of 6000 diameters, can spot units of gold so small that 40 billion of them would be worth only one cent. In June of 1938 German technicians announced perfection of a super-microscope using beams of electrons instead of waves of light, with a magnification factor of 20,400. Electron beams are straightened in a magnetic coil, passed through the specimen to be studied, focused in another coil; impressions are made on photographic emulsion; voltage used is 80,000. The magnification of this German instrument compares to that of ordinary high power microscopes about as the size of a penny compares to that of a pinhead. Instruments of this same general type were soon manufactured in this country by several industrial companies but the price was prohibitive for most universities or industrial concerns. A smaller sized model is now on the market for about \$900. This price is very attractive but it may be that the same situation exists as was experienced in the field of spectroscopy when the market was flooded with small and medium sized spectroscopes. The purchaser often obtained one of these before he knew their real limitations, and frequently he was bitterly disappointed when the required work was just too complicated to be handled by a small instrument. There is little doubt that the electron microscope is a very powerful and useful tool in many fields of science but some of the claims at the present time might be classed as highly optimistic if not extravagant.

5. A very interesting but not fully recognized method of microanalysis particularly applicable to the study of ores and minerals is the contact print method introduced by Gregoire Gutzzeit in March 1942. This is a combination of a number of methods in common use and includes the techniques of etching as used by the metallurgist, spot tests as used by the chemist, and micro-electroanalysis. It offers very interesting possibilities and will doubtless become used more often once it has become more widely known. The method is a modification of etching tests sometimes used in the identification of ores but offers an advantage over such tests. Both the etch and the contact print method are used when working with opaque ores and minerals. In the etch tests a polished section of the material to be studied is prepared and this surface is then treated with different chemical reagents to determine which of the constituents of the material are attacked by different reagents. Etch procedures are rather slow and are reliable only in the hands of an expert. Their greatest disadvantage is that the polished surface is destroyed with each test, thus making any further microscopic examination impossible without re-grinding and repolishing. The new face being different from the first one, no localization of the elements is possible.

In the contact print method use is made of specific organic reagents which give colored complexes with one or more elements. The procedure used is as follows: "A piece of gelatin-coated paper is impregnated with a selective attacking reagent. It is then placed on top of the polished surface and pressed down in contact with the specimen. After the paper is removed it is developed in a reagent that is specific for the questionable ion. An inverted image of the position of the element on the polished surface thus results."⁴ The paper may be either Eastman Kodak Co. "Kind 867" or a glossy photographic paper treated with thiosulphate and thoroughly washed in order to remove the silver salts.

This method has the advantage of giving a true picture of the localization of each element on the polished surface. It shows the presence or absence of a given element in each mineral particle by one test only, while by etch tests or microcrystalline tests

4. A.I.M.E. Mining Technology, T.P. 1457, p.2, March 1942

each mineral grain must be tested separately. Usually about ten prints can be made with one polish and it is easy to restore the original smoothness by rubbing the specimen on felt. In some instances electrolytic dissolution of the mineral is accomplished but this is limited to those minerals which are conductors of electricity. This is accomplished by connecting the mineral to the positive pole of a battery. The gelatin paper, soaked with an attacking reagent (an electrolyte), is pressed down on the polished surface by means of a metal foil which is connected to the negative pole of the battery. To prevent too rapid corrosion of the mineral the intensity of the electric current must be less than 50 milliamperes. Generally a potential from 2 to 6 volts is sufficient. Gutzeit's publication gives a large number of specific reagents and procedures; this article is recommended to scientists working in the field of mineralogy.

6. Analysis by means of the polarograph is rapidly taking its proper place in the field of chemical analysis. This type of analysis is based on the fact that various ions require different potentials for their discharge on a cathode. An electric cell containing a solution of the ions to be determined is subjected to a slowly increasing voltage and the current is plotted against the cathodic potential. When the potential reaches the discharge potential for a cation (positively charged ion) there will be an increase in the current at this point which will result in a sharp break in the plotted curve.

7. Spectrochemical Analysis. Like all other branches of analysis this technique has certain advantages over other types of analysis, but it has definite limitations.

As a means of making rapid and exhaustive qualitative analyses of all of the metals and a few of the non-metals it is unequalled. Using a spectrograph, one can make analyses in an hour which would take days, weeks, or even months by other methods; for example:

- a. The qualitative and quantitative analysis of hafnium in the presence of zirconium.
- b. The qualitative and quantitative analysis of rhenium in the presence of manganese.
- c. The quantitative analysis of samples for small amounts of such elements as beryllium, tin, zirconium, gallium, rubidium, cesium, and lithium.
- d. The detection and quantitative estimation of rubidium in the presence of excessive amounts of potassium or the detection and quantitative estimation of cesium in the presence of excessive amounts of sodium; and small amounts of strontium in the presence of barium and calcium.
- e. It is the only completely satisfactory method for the analysis of the rare earths particularly when there are several of this group present in the same sample, this being the usual experience.

The limitations of this method are almost entirely in quantitative work. Quantitative determinations always have a limit of accuracy which usually runs around 10 percent error in routine analysis. For constituents which run 10 percent or more in a sample, some other type of analysis is usually better but, as the percentage of the desired constituent decreases in the sample, spectrographic analysis becomes more applicable and, at 0.1 percent and lower, it is usually more accurate than other quantitative methods. In routine analysis the time necessary to set up a procedure is an important matter. But in routine analysis on the same type of sample day after day the method is unexcelled both in accuracy and in time.

8. Fire Assay. This is probably the oldest known method of analysis. It is really a small scale method of smelting. Analysts in the western part of the United States are more familiar with this method than chemists in the East. It is the most satisfactory method for the analysis of ores for such metals as gold and silver and the platinum group of metals (platinum, palladium, ruthenium, rhodium, iridium, and osmium). When used in conjunction with spectrography, extremely small quantities of these metals can be detected and quantitatively determined.

At the present time there is no one method of analysis which might be termed a universal "cure-all." Each known method has its own particular field and each method has its limitations. By recognizing this fact and by using all of the methods applicable to any problem the analyst can go far toward getting the correct answer. This is an age of mechanization, and analytical chemistry is rapidly following the trend. A student of analytical chemistry who intends to continue with this field as his profession would do well to learn as much as possible about optics and electrical set-ups, which of course include amplifying systems, and to acquire at least a nodding acquaintance with some of the analytical methods used in fields outside of his own specialty. If he is well grounded in the principles of mathematics, physics, and chemistry, he has a foundation upon which to build when he is suddenly thrust into other fields of science, and it usually happens that a graduate seldom does all of his industrial work entirely within his own rather narrow specialty.

HARRISON COMMISSIONED IN NAVY

Dr. H. C. Harrison, Chief Chemist in charge of the Department's spectrographic laboratory, has been commissioned lieutenant in the Navy and left on May 11 to engage in specialized work. Dr. Harrison, who received degrees from Washington and Lee and Cornell Universities, came to the Department in 1942 from the New York State College of Ceramics where he was professor of chemistry. He installed the Department's 3-meter grating spectrograph made by Baird Associates, and set up analytical techniques for the great variety of materials received for analysis. In addition to mineral and metal products, these materials included poisons, samples used as evidence in crime detection cases, and vegetation samples relating to agricultural research.

Miss Esther Miller, ceramic engineer and formerly assistant to Dr. Harrison, has taken over the spectrographic work of the Department.

BLAST HOLE DIAMOND DRILLING

A particularly interesting and useful booklet for mining engineers has been issued by J. K. Smit & Sons, 157 Chambers St., New York, dealers in diamond drill bits. This illustrated booklet traces the development of diamond blast hole drilling and fully describes such applications at many of the large Canadian mines including Noranda, Aldermac, Waite Amulet, Flin Flon, Howe Sound, and Steep Rock Iron Mines. A discussion of drilling equipment is included. The publication is sent free of charge on request.

STATE DEPARTMENT OF GEOLOGY & MINERAL INDUSTRIES
Head Office: 702 Woodlark Bldg., Portland 5, Oregon

State Governing Board

W. H. Strayer, Chairman	Baker	F. W. Libbey	Acting Director
Niel R. Allen	Grants Pass	John Eliot Allen	Geologist
S. H. Williston	Portland	Esther W. Miller	Ceramic Engineer

State Field Offices

714 E. H Street, Grants Pass	2033 First Street, Baker
W. A. G. Bennett Field Geologist	Norman S. Wagner Field Geologist

FLUORSPAR

Introduction:

Fluorspar, known in works on mineralogy as "fluorite," is a mineral important to several industries. Its greatest use is in the steel industry, where it is essential as a flux; therefore it is most important in the war program. In the chemical industry, it is the basic material from which hydrofluoric acid is made, and in the ceramic industry it is used in the manufacture of opal glass and enamels. Perfect crystals of fluorspar are of value in the making of optical instruments. Although the physical properties of fluorspar are of importance to the optical industry, in most of its uses fluorspar is employed for its chemical properties, specifically, for its low melting point and its fluxing ability. In fact, the name fluorspar is derived from the Latin word "fluere" which means "to flow."

In industry, fluorspar is frequently referred to as "spar."

History:

The first recorded use of fluorspar was in 1529 when Agricola wrote of its use as a flux. In these early days, the mineral was thought indispensable to smelting operations. Early in the 19th century, however, when improvements had been made in metallurgical methods and equipment, limestone took the place of the rare and costly fluorspar, except in the smelting of highly refractory ores.

Fluorspar was first used by prehistoric folk or by the Indians who took advantage of its beautiful colors and its transparency in the making of jewelry and ornaments. It was produced commercially in the United States for the first time in 1837 when it was mined from a topaz vein near Trumbull, Connecticut, and used in the smelting of copper ores. The mineral at that time sold for \$60 per ton. Although the presence of fluorspar in the Illinois-Kentucky district was recognized for several years previously, the first mining of the now-famous deposits began in 1842; the first shipments were made in 1871. The Royal mines in western Kentucky furnished the ore, which was ground at the mines and then shipped to glass works in Baltimore.

In the United States, the manufacture of glass and of hydrofluoric acid absorbed the greatest tonnages of the available fluorspar until 1898. Then as the mineral was needed as a flux and cleansing agent in the basic open-hearth process for steel, fluorspar began to show its importance to the steel industry. Within a few years this new process absorbed a greater tonnage of fluorspar than the older uses; in recent years the tonnage used in the making of steel has soared to 80 percent of the total yearly domestic production.

Even before the first world war, the nation depended upon the Illinois-Kentucky field for the bulk of its fluorspar. With the beginning of World War I, a great demand arose for fluorspar, and small deposits all over the country were developed and mined for this mineral. After the end of the war, however, many small mine owners found further mining unprofitable. Since 1918, at least 90 percent of our domestic supply of fluorspar has been derived from the Illinois-Kentucky field, with about 5 percent coming from Colorado.

Physical and chemical properties:

The chemical composition of fluorspar is CaF_2 , calcium fluoride. It represents a hardness of 4 in Mohs' scale, being harder than calcite (3) and softer than apatite (5). Fluorspar crystallizes in the isometric system, often forming perfect cubes, and also having excellent octahedral cleavage. Its specific gravity is 3.18, and its melting point lies between 1270° and 1387° C.; pure calcium fluoride melts at 1387° C. The fracture surface is conchoidal or splintery. When the mineral is crystalline, its luster is vitreous; when granular, it is dull or earthy.

Fluorspar ranges in color from the clear, colorless crystal through many shades of yellow, green, brown, pink, violet, and purple. The reason for the differences in color is not known. The mineral may be transparent, translucent, or opaque, depending upon the form in which it is found. It is rarely contaminated with impurities, and is usually found as a mass of very pure crystalline material, with vugs containing aggregates of cubical crystals. It may also be found in granular form, varying from fine to coarse. Other forms are banded veins or fibrous masses with radiating structure. Some specimens of fluorspar will fluoresce under an ultraviolet light, while others exhibit phosphorescence when heated or scratched.

Fluorspar can be differentiated from calcite by its failure to effervesce when treated with dilute hydrochloric acid.

Geological associations:

Fluorspar is found under widely different conditions and in all kinds of rocks. It is most abundant in veins and in sedimentary formations, but is also found in small quantities in granite, syenite, pegmatite, gneiss, and schist, and may appear even in volcanic rocks. It may be associated with calcite, barite, quartz, galena, and sphalerite. It is a common gangue mineral of ore deposits, particularly those of lead and zinc ores formed under moderate to low temperatures and pressures. Frequently it is not feasible to determine whether a deposit of this sort may be worked primarily for the lead and zinc or for the fluorspar "gangue."

Lindgren (Mineral Deposits, 4th ed.) considers fluorspar to be one of a group which he terms "persistent" minerals. These, he says, seem to be less sensitive than others to physical conditions and recur in very different environments. Fluorspar is found in ore deposits formed by magmatic separation, contact metamorphism, and deposition in veins as a result of circulating hydrothermal solutions. It is also found, together with galena and sphalerite, at moderate to shallow depths in sedimentary rocks. Some geologists consider these latter deposits to have their origin in rising magmatic solutions, while others believe that circulating meteoric waters furnished the materials for the deposits.

The following discussion of the conditions under which fluorspar is found has been derived largely from U. S. Bureau of Mines Bulletin 244.

1. Almost all the important deposits of fluorspar are either in or near fault zones. They are either vein fillings, replacements of the wall rock, replacements of sedimentary beds (particularly limestones) near fault fissures, or fillings of solution cavities near faults. Weathering of the more soluble minerals of the vein may produce residual deposits of fluorspar called "gravel-spar."

2. Almost all the important deposits of fluorspar are found in limestones or calcite veins. Calcareous beds seem to favor the formation of large, rich deposits of the spar. In the Illinois-Kentucky field where the faults cut calcareous beds, such as limestones and limy shales and sandstones, or where the faults were originally filled with calcite, the deposits of fluorspar are widest and best. However, where the faults cut through highly siliceous beds, the deposits pinch and decrease in value.

Although most deposits of fluorspar in igneous rocks are of small extent, at Wagon Wheel Gap, Colorado, the fluorspar occurs in Tertiary volcanic rocks, forming the largest and most persistent deposit known in igneous rocks. That there is lime in this area, however, is shown by the fact that the Wagon Wheel Gap vein, if projected, would cut a deposit of travertine not far away.

3. Almost all the important deposits of fluorspar either show, or are found near, evidences of igneous activity. Such evidences may take the form of intrusive dikes, hot mineral springs, or similar features. It seems probable that, in most deposits of fluorspar, the fluorine, together with the other elements that form the vein, was brought up by ascending hot magmatic solutions. The calcium fraction of the fluorspar may have been brought up in the same solutions or may have been derived from the calcareous beds cut by the fault. It is not to be assumed, however, that all deposits of fluorspar were formed in this way.

In large deposits the fluorspar tends to be white and gray, while in the smaller veins and in siliceous rocks the fluorspar may be green and purple, particularly near the surface. The reason for this variation in color is not known.

Deposits in the United States:

The fluorspar-producing area which for years has furnished the United States with at least 90 percent of her needs, and which is probably the greatest fluorspar deposit in the world, is an area about 40 miles square straddling the Ohio River in Illinois and Kentucky. The field is underlain by nearly horizontal Paleozoic sedimentary beds cut by many steeply dipping normal faults and by dikes of altered volcanics. The fluorspar is found either in veins occupying the nearly vertical fault fissures or in horizontal, tabular bodies or lenses.

Most of the production of fluorspar from this area has come from the vein deposits. The total production is estimated at more than 2,500,000 tons. The veins, ranging in width from a fraction of an inch to 30 feet, are composed mainly of fluorspar and calcite. Fluorspar has been found more than 720 feet underground in Illinois, and at depths greater than 400 feet in Kentucky. At depth, however, the fluorspar may decrease in amount and give way to calcite. The veins probably underwent two periods of deposition: first, vein filling, and second, replacement of calcareous material of the wall rock.

The tabular or lenticular deposits, known as "bedding," "bedded," or "blanket," deposits, have produced more than 100,000 tons of fluorspar, and reserves may be estimated at many times this tonnage. Fluorspar, in light and dark colored bands, has replaced the upper beds of the Fredonia limestone of Mississippian age near Cave In Rock, Illinois. A roof of nearly impervious shale prevented the further ascension of hot mineralizing solutions which rose along minor fissures. The solutions were forced to spread out fan-wise beneath this stratum, replacing the limestones with fluorspar. The Cave In Rock district lies just east of the highly faulted zone in which the vein deposits of fluorspar are so notable. The fluorspar-forming solutions may have spread from these major fractures to the smaller outlying faults. The tabular deposits range in thickness from a few inches to more than 12 feet; the average thickness mined is about 4 feet. Vugs containing aggregates of perfectly formed fluorspar crystals have been found in these bedded deposits.

Fluorspar is mined on its own account at several places in Colorado, including Wagon Wheel Gap, Jamestown, North Gate, and Brown Canyon. It is also found in metaliferous ore deposits as a gangue mineral. A basic open-hearth steel plant at Pueblo furnished the first major market for Colorado spar.

According to Minerals Yearbook, 1941, shipments of fluorspar from 1870, when production began, to 1941 total 4,848,000 short tons. Of this tonnage, Illinois furnished 56 percent and Kentucky, 36 percent. Colorado has shipped approximately 5 percent of this total.

Fluorspar is found and mined in many other places in the United States, but none has reached the prominence of the Illinois-Kentucky field. Central Kentucky, New Hampshire, and Tennessee boast a small production of the mineral. In the western United States, much of the fluorspar is found in igneous rocks, and, although many of these deposits are too low in value to permit mining, commercial production has been reported in Arizona, California, Nevada, New Mexico, Utah, and Washington.

Foreign deposits:

On the American continent, fluorspar is mined in Canada, Newfoundland, Mexico, and Argentina. On the European continent, it is produced in England, France, Germany, Spain, and Italy. The English deposits are found in Derbyshire, Durham, Cornwall, Devon, and North Wales. In Derbyshire, the veins, which cut Paleozoic limestones, average 6 feet in width. They were mined originally for lead, the fluorspar gangue being left in waste heaps. Later, however, the fluorspar was extracted from this waste material. Fluorspar is abundant in several places in Germany; mining is efficient and near-by markets are excellent. Africa, China, and Australia also produce some fluorspar.

Uses:

Fluorspar used in the steel industry must contain not less than 85 percent CaF_2 and not more than 5 percent SiO_2 . The sulphur content must be kept below 0.3 percent. The grade of fluorspar used in metallurgy is known as "gravel," which is not to be confused with the gravel-spar formed by surface weathering. The size of the gravel fragments, although usually from 5/8-inch to dust, actually depends on the nature of the fluorspar deposit and on the milling process.

Fluorspar is of value in the basic open-hearth process because of its low melting point and its fluidity when melted. It has the ability to lower the melting point of the slag by forming eutectics with silica, calcium and barium sulphates, alumina, and other refractory materials, thereby rendering the slag fluid and easy to handle. Furnace temperatures can be lowered and the whole operation is facilitated. Because of the increased fluidity of the slag, the gases from the metal may escape easily; harmful impurities such as sulphur and phosphorus are removed by volatilization and by slagging. The chemistry of the reactions that occur when fluorspar is employed as a flux are not fully understood. The fact remains, however, that fluorspar is more efficient as a flux in this process than limestone, especially when refractory ores are to be smelted, and is more useful than its best substitute, calcium chloride.

An open-hearth furnace has, on the average, a capacity of 50 to 60 tons. First, a quantity of limestone, weighing about one-tenth of the weight of the metal charge, is spread over the bottom. Then the pig iron and scrap are added, and the heating begins. When the melting of the charge is complete, the limestone rises through the charge to the top and floats on the surface. As heating continues, this slag may become a thick mass which prevents the escape of gases from the melted charge. Fluorspar is then added to increase the fluidity of the slag. Operators differ as to the time at which the fluorspar should be introduced; some add it in small quantities throughout the melt but others add it just before tapping. The amount of fluorspar used per ton of steel ranges from 4 lb. to 25 lb., but averages 5 to 8 lb.

Fluorspar has several other uses in the metallurgical industry. It is used in iron foundries as a flux in the production of the finer grades of castings, such as heating and plumbing equipment, and automobile cylinders and blocks. Some electric-furnace plants find a use for fluorspar in making alloy steels in which it performs the same function of a flux as in the basic open-hearth steel process. The quantity used averages 20 lb. per ton of steel. The fluorspar used for making ferro-alloys in electric-furnace plants must be high in CaF_2 and low in SiO_2 , and is usually lump size ranging from 5 to 6 inches in diameter to dust. The production of nickel and monel metal, as well as the smelting of refractory ores, requires small quantities of fluorspar.

The chemical industry requires fluorspar mainly for the manufacture of hydrofluoric acid. Acid-grade fluorspar must contain a minimum of 98 percent CaF_2 and a maximum of 1 percent each of silica and calcium carbonate. Objectionable impurities are lead, zinc, and iron minerals. Acid spar may be ground at the mines, or may be shipped in lump and gravel sizes. The acid is produced by treating ground fluorspar with concentrated sulphuric acid. Hydrofluoric acid is used in etching glass and in making fluorine compounds, the inorganic and organic fluorides and the silico-fluorides. Many fluorine compounds are used industrially in preservatives, insecticides, and dyestuffs. "Freon," dichlorodifluoromethane, a new refrigerating medium, is nonexplosive, noninflammable, and almost nonpoisonous. Fluorspar is also employed in the manufacture of artificial cryolite. The fluorspar is used to produce hydrofluoric acid, which in turn is used to make the synthetic cryolite, a sodium aluminum fluoride. Aluminum is then recovered by electrolytic methods from a combination of natural and artificial cryolite.

Fluorspar is also used in the chemical industry in the extraction of potassium from feldspar and from portland cement flue dust; it is also used in the manufacture of calcium carbide and cyanamid.

In ceramics, fluorspar is valued for its ability to produce cloudy or white opaque glass. It is also employed in the manufacture of enamels, facings for brick, and portland cement. Ceramic spar must contain from 95 to 98 percent CaF_2 and not more than 3 percent SiO_2 . It must be pure white when ground, and free of lead, zinc, and sulphur impurities.

A very small amount of fluorspar is absorbed each year by the optical industry. Optical spar must be as clear as glass, with no inclusions, cracks, incipient cleavage marks, or cloudiness. Colorless crystals are best, although those with faint tinges of yellow or green may also have value. Because of its low index of refraction, its weak color dispersion, and its lack of double refraction fluorspar is used to correct lenses for color and spherical aberration. The lenses are used in spectrosopes, microscopes, and small telescopes. Colored fluorspar crystals, although relatively soft, may be made into jewelry. Optical spar is found in places in Illinois and Kentucky.

The following table, taken from Minerals Yearbook, 1941, gives the tonnages of the fluorspar shipped from mines in the United States in 1940-41, by uses:

Use	1940		1941	
	Percent of total	Short tons	Percent of total	Short tons
Steel	69.68	162,772	66.77	214,120
Foundry	1.21	2,829	.85	2,724
Glass & enamel	8.68	20,269	9.99	32,051
Hydrofluoric acid	14.39	33,608	16.43	52,674
Miscellaneous	2.41	5,640	2.16	6,916
	<u>96.37</u>	<u>225,118</u>	<u>96.20</u>	<u>308,485</u>
Foreign consumption	3.63	8,482	3.80	12,184
	<u>100.00</u>	<u>233,600</u>	<u>100.00</u>	<u>320,669</u>

Prospecting, mining, and milling:

Deposits of fluorspar may be recognized on the surface by the presence of gravel-spar, the result of surface weathering of fluorspar-rich deposits. In an area of known vein deposits, a search for faults may disclose new fluorspar-bearing veins. In the Illinois-Kentucky field, prospecting by geophysical methods has brought to light concealed faults which may prove to contain spar. In the West, the presence of fluorspar sand in anthills, or as a gangue mineral in metalliferous veins may indicate commercial deposits.

The nature of the deposit and the skill of the operator determine the method of mining. Usually, fluorspar is mined underground, as metallic ores are mined. However, where gravel-spar is sufficiently rich it may be mined by open-pit methods. These deposits are now being worked extensively owing to the increased demand of the steel industry for spar.

Industrial Minerals and Rocks (1937) gives these methods of preparation of the ore: selection in the mine, crushing, washing with jets of water or in log washers, hand picking on belts, screening, gravity concentration by jigs and tables, and flotation. The method of milling would depend in part upon the nature and quantity of the impurities. The character of the ore and the use to which it is to be put also affect the milling process. Although some deposits are so pure that a marketable product can be obtained by hand cobbing and sorting, most deposits need a more thorough preparation for market. Some impurities, such as calcite, quartz, clay, and sand, are not actually harmful although they reduce the calcium fluoride content of the finished product. Others, such as barite, galena, sphalerite, and pyrite, are definitely objectionable, and must be removed by one method or another before the spar can be shipped.

Prices:

In the United States in 1941, the average composite selling price of all grades of fluorspar (both domestic and imported), as delivered to the consumer, was \$20.98 per ton. This is only slightly above the 1940 composite price of \$20.40. The average selling price of fluorspar shipped to domestic steel plants, f.o.b. Illinois-Kentucky mines, was \$19.62 a short ton; to manufacturers of hydrofluoric acid, \$26.78; and to makers of glass and enamel, \$27.39. On January 20, 1942, the Office of Price Administration asked producers not to sell fluorspar, or publish or quote prices on the mineral, above the prices in effect on January 2, 1942. However, since that date substantial increases in price have been granted, giving impetus to the previously lagging production.

The War Production Board rates fluorspar in Group I among the materials in insufficient supply to satisfy war plus essential industrial demands. Government purchases of the mineral made through the Metals Reserve Co. are f.o.b. the railroad point nearest the mine at a price based upon "Effective CaF₂ Content." This is determined by deducting 2½ times the silica (SiO₂) content from the total CaF₂ content. For metallurgical grade the maximum price for effective CaF₂ content is the amount listed below plus either (1) railroad freight from producer's shipping point to the producer's plant, or (2) railroad freight from Rosiclare, Illinois, to consumer's plant, whichever is lower:

<u>Effective CaF₂ content</u>	<u>Base Price per short ton</u>
70% or more	\$33.00
65% but less than 70%	32.00
60% " " " 65%	31.00
Less than 60%	30.00

For acid and ceramic grades the base analysis is 95.5% CaF₂ and 1.5% SiO₂ with base price of \$37.00 per ton plus railroad freight as computed for metallurgical grade. Premiums are given and penalties imposed for variations from the base analysis. Specifications may be obtained from Metals Reserve Company.

World production:

About four-fifths of the total annual world production of fluorspar is furnished by the United States, Germany, France, the United Kingdom, and the U.S.S.R. From 1913 through 1926, the United States produced more fluorspar annually than any other country. In 1927 Germany led the world in fluorspar production. Since that time the lead has alternated between Germany and the United States. For years Germany furnished the bulk of the fluorspar imported into the United States, but recently, and with good reason, this supply has been cut off. In 1941 fluorspar was imported from Mexico, Spain, the United Kingdom, and other Allied and non-belligerent nations.

Within the last few years the tonnage of fluorspar shipped within the United States has almost doubled. In 1939, 165,806 tons was shipped; in 1940, 211,917 tons; and in 1941, 290,095 tons. Although production statistics of the Axis nations are lacking, the United States probably leads the world in production, importation, and consumption of fluorspar.

References:

Most of the material in this article was derived from:

Industrial minerals and rocks, A.I.M.E., 1937.

Fluorspar; its mining, milling, and utilization, U.S.B.M. Bulletin 244, 1927.

The fluorspar industry of the United States, Illinois State Geol. Survey Bull. 59, 1938.

Minerals Yearbook, 1941, U.S.B.M.

Other data were gathered from:

Economic geology of mineral deposits, Ernest R. Lilley, 1936.

Getting acquainted with minerals, George L. English, 1934.

Mineral raw materials, 1937.

Mining and Metallurgy, February 1944.

Joyce B. Priestaf

CHROME MINING ACTIVITY

The Sourdough Chrome mine on Baldface Creek, Curry County, which was formerly owned and operated by Rustless Mining Corporation, has been taken over by Mr. J.K. Remsen and is currently being operated by a crew of four men under the supervision of Ben Baker. Remsen reports that 66 tons of low-iron ore running about 45% Cr₂O₃ has already been delivered to the Metals Reserve depot at Grants Pass and that the prospects for more ore of better grade are good.

* * * * *

The Cyclone Gap property in Siskiyou County, northern California, which has been operated by Remsen for the past three years, will be reopened next week when a crew of three or four men will start a drift to the east from the present ore body to determine if any additional ore can be obtained.

* * * * *

The Grey Eagle Chrome mill, formerly operated by Rustless Mining Corp., 30 miles west of Willows, California, has been sold to a mining company in New Mexico which intends to use it for concentrating manganese ore. The Grey Eagle mill ceased operations this spring after exhausting a large body of low-grade chrome ore.

* * * * *

John Robertson continues to ship good chrome ore from the Illinois Chrome mine on the Illinois River 18 miles west of Selma, Oregon. Production is at the rate of about 700 tons a month, and the ore is trucked to the Metals Reserve Company purchasing depot at Grants Pass.

UNITED STATES MERCURY PRODUCTION, 1943

According to Mineral Market Report No.1191 released by the U.S.Bureau of Mines, June 10, 1944,

"The mercury output in 1943 totaled 51,929 flasks which represented a new peak rate since 1882. This high production was in response to the stimuli provided by historic peak prices, Government buying and other aids and was made despite labor shortages and inefficiency, and other handicaps. The opening of the New Idria-Alaska (Red Devil) mine, Alaska, on a larger scale in 1943, the attainment of peak annual production at the New Idria mine, Calif., after more than 80 years operation, the almost quadrupling of output at the Abbott mine, Calif., the substantial gain at Mt. Jackson mine, Calif., and the almost doubling of large-scale production at the newly opened Hermes mine, Idaho, were the principal factors that erased the losses at many other mines and accounted for the increase already noted.

Mercury Produced in the United States, 1942-43, by States

	1942			1943		
	Producing mines	Flasks (76 pounds)	Value <u>1/</u>	Producing mines	Flasks (76 pounds)	Value <u>1/</u>
Alaska	(2/)	(2/)	(2/)	3	786	\$ 153,435
Arizona	7	701	\$ 137,641	3	541	105,609
Arkansas	16	2,392	469,669	18	1,532	299,062
California	85	29,906	5,872,043	65	33,812	6,600,440
Idaho	(2/)	(2/)	(2/)	1	4,261	831,790
Nevada	40	5,201	1,021,217	33	4,577	893,476
Oregon	23	6,935	1,361,687	16	4,651	907,922
Texas	(2/)	(2/)	(2/)	7	1,769	345,326
Utah	(2/)	(2/)	(2/)	-	-	-
Washington	(2/)	(2/)	(2/)	-	-	-
Undistributed	13	5,711	1,121,355	-	-	-
	184	50,846	9,983,612	146	51,929	10,137,060

1/ Value calculated at average price at New York. 2/ Included under "Undistributed", Bureau of Mines not at liberty to publish."

* * * * *

"The average grade of ore treated rose in 1943, against the historic trend. In 1943 the grade was 0.31 percent (6.28-pound ore), compared with 0.25 percent in 1942 (5-pound ore), 0.26 (5.2-pound ore) in 1941, 0.31 (6.2-pound ore) in 1940, and 0.37 (7.4-pound ore) in 1939."

COAL SHORTAGE

Addressing the National Association of Purchasing Agents this week Deputy Solid Fuels Administrator Charles J. Potter estimated a bituminous coal shortage of 30 million tons this coming winter (596 million tons production against 626 million requirements), with an 8 million ton shortage in anthracite. Potter stated that recourse can be had to three measures, (1) reduce consumption by domestic consumers, (2) substitute less desirable coal in many services, and (3) cut down on industrial consumption. He stated that the first two measures are being followed out in varying degree and forecast the possibility of either a curtailment in the supply in non-essential industries or a general cut-back affecting all industries.

From Bulletin Service, The American Mining Congress, June 2, 1944.

STATE DEPARTMENT OF GEOLOGY & MINERAL INDUSTRIES
Head Office: 702 Woodlark Bldg., Portland 5, Oregon

State Governing Board

W. H. Strayer, Chairman	Baker	F. W. Libbey	Acting Director
Niel R. Allen	Grants Pass	John Eliot Allen	Geologist
S. H. Williston	Portland	Esther W. Miller	Ceramic Engineer

State Field Offices

714 E. H Street, Grants Pass	2033 First Street, Baker
W. A. G. Bennett Field Geologist	Norman S. Wagner Field Geologist

MINERAL RIGHTS IN REVESTED OREGON LANDS

by

Irving Rand
State Senator

The mining industry of western Oregon is seriously affected by an interpretation placed by the Secretary of the Interior upon the acts of Congress relating to the re-vested Oregon and California Railroad lands and the reconveyed Coos Bay Wagon Road grant lands. These lands aggregate approximately two and a half million acres, in alternate sections generally, in the counties of Josephine, Jackson, Curry, Coos, Douglas, Lane, Linn, Benton, Marion, Polk, Clackamas, Yamhill, and some others. Within this vast area, from the Columbia River on the northerly boundary of Oregon to the California-Oregon boundary on the south, there are in all reasonable probability many as yet undiscovered mineral deposits of various kinds and of great value.

When the Oregon and California Railroad grant lands became "revested" in the United States, the Congress on June 9, 1916, passed an act providing for the classification of these lands as timber lands, power-site lands and agricultural lands, and for the disposal of the agricultural lands and of the timber on the timber lands. Section 3 of this act provides that this classification shall not operate to exclude from exploration, entry and disposition under the mineral land laws of the United States any of these lands (except power sites) which are chiefly valuable for their mineral deposits, and the general mineral land laws are extended to all such lands, except power sites. The timber on mining locations is reserved to the United States, subject to the right of the locator to use the timber necessary in mining his claim.

In 1919 the Congress passed another act accepting the lands in Coos and Douglas Counties granted to aid in the construction of a military road to Coos Bay Wagon Road Company, and providing that these lands shall be classified and disposed of in the manner provided by the act of June 9, 1916 for the classification and disposal of the O. & C. grant lands.

Consequently, until 1937 at least, these revested lands and reconveyed lands were open to mineral entry and location the same as other portions of the public domain.

On August 28, 1937, the Congress passed another act relating to these lands, providing that such portions of them as are classified as timber lands shall be managed for permanent forest production, and the timber shall be sold, cut, and removed in conformity with the principle of sustained yield for the purpose of providing a permanent source of timber supply.

The Secretary of the Interior has ruled that this act of August 28, 1937, has impliedly repealed section 3 of the original act of June 9, 1916, thereby precluding any mineral locations on any of the revested or reconveyed lands, except possibly lands classified as agricultural. As a result of this ruling the General Land Office through the District Land Office has notified mineral claimants whose claims were located subsequent to August 28, 1937, that their claims are "null and void."

If this ruling is adhered to and becomes "the law of the land" the great area involved will forever be closed to mineral exploration and development, and its mineral wealth will remain unfound and unused.

Senator Cordon has recently introduced legislation in the Congress to remedy this situation and to return these lands to their rightful status as potential producers of mineral wealth. Senator Cordon and the Oregon congressional delegation should receive the active and vigorous support of all citizens of Oregon in this legislation. The timber resources of the region will not be adversely affected, since as stated, the act of June 9, 1916 reserves the timber on the mining claims to the United States.

MERCURY IN MAY 1944

Mercury production continued to decline in May and consumption followed a like pattern, according to the Bureau of Mines, United States Department of the Interior. The production of 3,400 flasks marked a drop of 23 percent from the January rate, whereas consumption of 3,100 flasks more nearly approximated the rates for the earlier months of the year. The quoted price dropped 10 percent in May continuing the movement in progress since September 1943. Operations of Requa at the Polar Star mine, San Luis Obispo County, California, were discontinued and the Pershing mine, Pershing County, Nevada, was closed in May.

Salient statistics on mercury in the United States in 1939-43 and in Jan.-May 1944, in flasks of 76 pounds each

Period	Production	Consumption	Stocks at end of period		Price per flask at New York
			Consumers and dealers <u>1/</u>	Producers <u>2/</u>	
Average Monthly					
1939.	1,553	<u>3/</u> 1,742	12,600	376	\$ 103.94
1940.	3,148	2,233	14,100	607	176.87
1941.	3,743	3,733	12,400	439	185.02
1942.	4,237	4,142	10,700	1,377	196.35
1943.	<u>4/</u> 4,327	4,542	13,200	3,457	195.21
Monthly					
1944:					
January . . .	4,400	3,400	11,300	5,459	151.60
February. . .	3,800	3,700	9,400	5,450	130.00
March	3,800	3,600	9,900	5,011	130.00
April	3,700	3,200	9,700	5,604	128.20
May	3,400	3,100	8,900	6,171	115.54

1/ Largely excludes redistilled metal. 2/ Held by reporting companies. 3/ Apparent consumption. 4/ Based on final figures.

MAP OF WESTERN OREGON
SHOWING
O. & C. LANDS

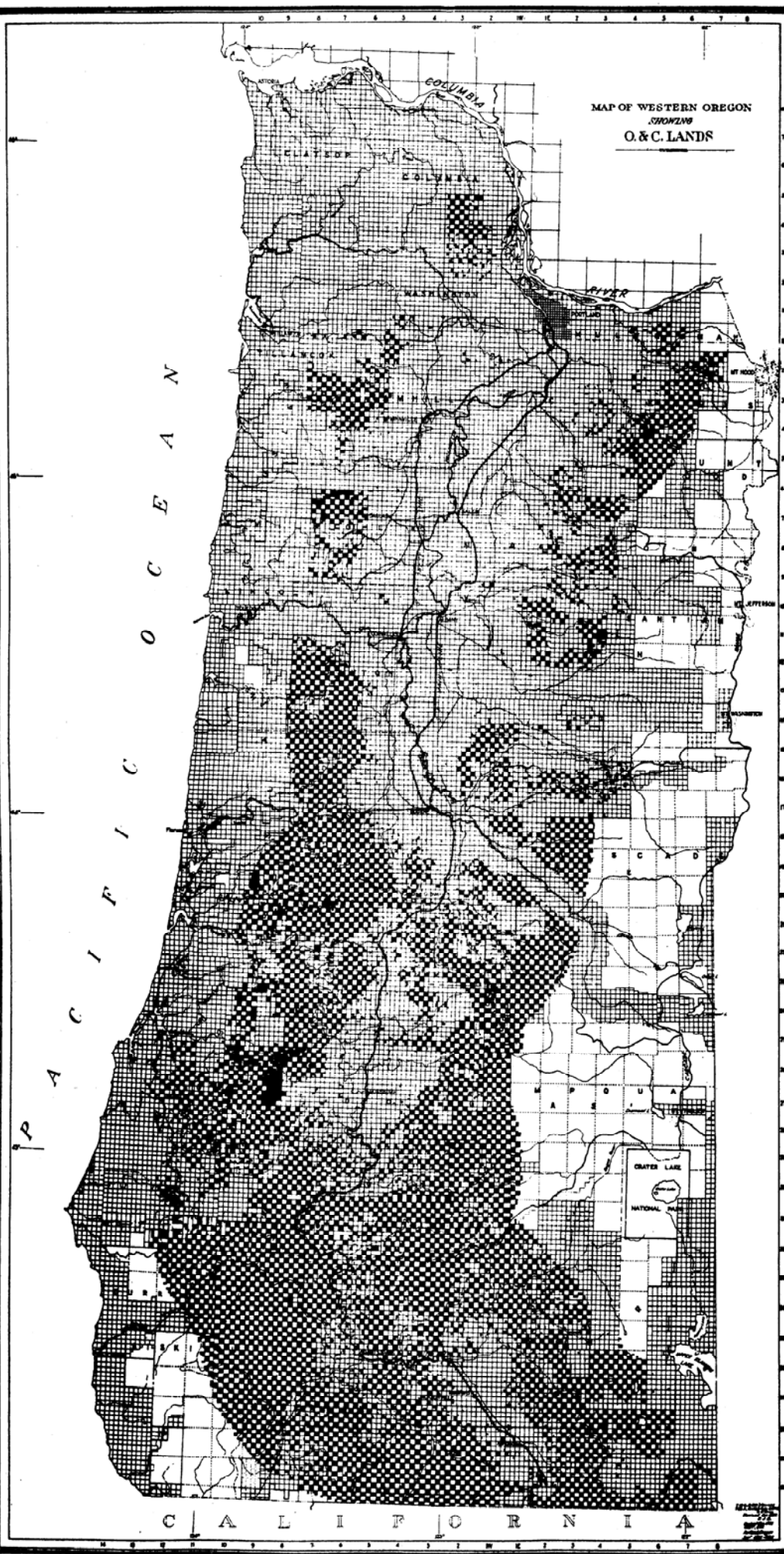

MINERAL LEASING BILL

Introduction:

H.R. 2279 was a bill designed to restore to the public domain, and to location and entry under the United States mining laws, such re-vested Oregon and California Railroad and recon-veyed Coos Bay Wagon Road grant lands as would be classified by the Secretary of the Interior as mineral lands. When asked for a report on this bill, the Secretary recommended that it be not enacted and submitted a proposed bill as a substitute for H.R. 2279 to provide for leasing the minerals in these lands.

Although this leasing bill, as recommended by the Secretary, applies specifically to O. and C. and Coos Bay Wagon Road grant lands only, it would undoubtedly serve as a model for mineral leasing on all the public domain if Congress could be persuaded to pass the necessary legislation. It is, therefore, of the utmost importance that the mining industry of the public land states examine the provisions of this proposed leasing bill and compare it with methods of acquiring mineral lands under existing United States mining laws.

The Bill:

Section 1 contains a statement authorizing the Secretary of the Interior to lease, for mining purposes, any of the described lands containing valuable deposits of minerals (except those not now subject to location under the mining laws); also to issue "temporary use permits for the mining and removal of common stone, rock, sand, gravel, clay, and other materials where they do not occur in quantity and of quality sufficient to justify their classification as valuable minerals....."

Section 2 provides for competitive bidding on leases in units not to exceed 640 acres "in reasonably compact form" on lands known to contain valuable mineral deposits not subject to "preferential lease" which is defined further along in the bill. Leases would be offered "to the highest responsible qualified bidder after notice and advertisement, upon such terms and subject to such conditions as the Secretary of the Interior may by general regulations prescribe. Any such lease offer shall reserve to the Secretary of the Interior the right to reject any or all bids whenever, in his judgment, the interests of the United States so require."

Section 3 contains a rather curious provision, namely "The Secretary of the Interior may issue separate leases for the concurrent development of deposits of different minerals underlying the same lands." (Underlining by Ed.)

Complications inherent in such an ingenious (or ingenuous) provision should be plain even to anyone inexperienced in mining. To put it mildly, this provision destroys confidence of the reader in the ability of the author of the bill to understand the problems involved.

Further in Section 3 it is specified that leases are to be set up for a period of ten years with the right of renewal "upon such reasonable terms and conditions as may be prescribed by the Secretary of the Interior"....."The amount of work to be done or investment required during each year of the lease shall be prescribed in the lease. The lease shall be conditioned upon the payment of an annual rental, payable in advance, of not less than 25 cents per acre for each year during the life of the lease, and a royalty to the Government. The rental paid for any one year shall be credited against the royalties as they accrue for that year. The royalty due shall be computed (1) at not less than 5 per centum of the value at the point of shipment to market of the mineral substances developed for disposal or (2) at not less than 5 per centum of the net returns from the processing plant or smelter or mint if the mineral substances are shipped as ore for processing, or as concentrates for smelting, or as bullion for minting. Such royalties shall be due and payable quarterly. The Secretary of the Interior may elect to take payments of royalties in mineral substances developed for disposal from the leased deposits."

The last sentence looks innocuous, but ask any miner who has ever done any leasing if he would sign a lease containing this clause. Moreover the meaning of "developed for disposal" in this sentence is ambiguous.

Section 4 provides that "temporary use permits" mentioned in Section 1 "shall be for a period of not exceeding one year and for not exceeding 640 acres in a reasonably compact form;....." Rental per acre and royalty are essentially the same as for the regular lease. These permits "shall be subject to revocation by the Secretary of the Interior after 30 days' notice upon failure of the permittees to comply with the terms of the permit or of any regulation."

No mention is made in this section of credit for rental against royalty as is provided for the regular lease in Section 3.

In section 5 the Government makes sure that no person, association, or corporation shall hold at any one time leases in the aggregate of more than 640 acres for any one of the minerals subject to appropriation under a lease.

Section 6 provides for forfeiture and cancellations whenever the lessee does not comply with any of the provisions of this act or of the lease.

Section 7 is quoted in full as follows: "Where prospecting is necessary to determine the nature and extent of a mineral deposit, the Secretary of the Interior may grant to any applicant qualified to acquire a lease under this Act a permit which shall give him the exclusive right for a period of not exceeding two years to prospect a reasonably compact area not exceeding 640 acres upon such conditions as may be provided. Any permittee who has expended not less than \$250 in prospecting on the land during the life of the permit, but has not made a discovery, shall, in the discretion of the Secretary, be entitled to a preferential right to a new permit for the land upon application filed prior to the expiration of the permit. If a permittee shall show to the satisfaction of the Secretary of the Interior that he has made within the period of the permit, a discovery of valuable mineral in the land described in the permit, he shall be entitled to a preferential right to a lease for all or a part of the area, to be selected in a reasonably compact form by the permittee, upon the terms provided in section 3 of this Act. After discovery is made on a permit and until a lease is applied for, the permittee shall pay to the United States not less than 10 per centum of the value of all minerals produced from the permit lands. A permit shall be assigned only with the approval of the Secretary of the Interior and shall be subject to revocation by the Secretary of the Interior after 30 days' notice upon failure of the permittee or his successor to comply with the terms of the permit or of any regulations."

The opening sentence of this section raises the question as to the nature of a mineral deposit where prospecting would not be necessary to determine its nature and extent. This point is of no special importance but again one wonders concerning the qualifications of the author of the proposed substitute bill.

Another point may be raised concerning the specification that "the permittee shall pay to the United States not less than 10 per centum of the value of all minerals produced etc." How is the "value" defined? Also 10 per centum is the stated minimum. What is the maximum and how is the amount determined?

It should be noted that should a prospector make a discovery and wish to transfer his rights to a buyer, he may do so only with the approval of the Secretary of the Interior.

Section 8 allows prospecting for gold, silver, and chromium in the reconveyed lands without a permit; "Provided, however, That if a prospector finds gold, silver or chromium, he shall stake an area not exceeding 20 acres conforming as nearly as practicable to the subdivisions of the public land surveys and shall post a notice thereon of his intention to explore the ground in an effort to develop a paying mine. He shall cause to be erected upon the land at some conspicuous place a monument not less than 4 feet high and shall post the notice on or near the monument. The notice shall contain the name of the mineral sought;

the name and address of the locator; the date of posting; a description of the land by legal subdivisions; and a statement that the locator will prospect the land and claim a preference right to a lease in the event that he makes a valid discovery. Within 30 days after posting the notice he shall file a copy in the United States land office for the district in which the land lies. Such staking, posting, and filing shall give the prospector the exclusive right to develop or mine the mineral within the area staked, and to use the surface only for mining operations, for a period of not longer than one year from the date on which the notice was posted on the ground. The prospector shall have a preferential right to lease the land, if prior to the expiration of the one year period he files an application for a lease under the provisions of this Act."

Hypothetical question: What is the status of the prospector if he works on a mineral showing for a year without finding pay ore and fails to make application for a lease within the prescribed time; and at the expiration of the year a second prospector posts the required notice on the ground, starts work, and finds pay ore because of the work of the first prospector? Well, it appears as if that would just be the first man's hard luck. But the writer of the bill ought to give him a better "break" even if said writer never got hard, calloused hands from handling a pick and shovel, or drill steel and single jack. In the present mining law there is no strict time limitation. So long as the prospector does a certain amount of work he maintains his possessory right in his claim.

Another question also will be raised by the experienced prospector. A not uncommon condition might occur in which the prospector makes a discovery and stakes his 20 acres. He then, over a period of time, traces a vein of low grade material to his boundary where, just beyond, a bonanza develops - but a second prospector, recognizing the possibilities from the other's early work, has already staked the ground containing the bonanza. The first man has proved up the other man's ground, but has no recourse. Under the U.S. mining laws he could have protected himself by locating two or more claims; under this leasing law he is restricted to "an area not exceeding 20 acres conforming as nearly as practicable to the subdivisions of the public land surveys." Incidentally this size specification is "blood relative" of the Federal placer mining law, and the author of the bill saw no need of making distinction between eccentricities of lode and placer deposits.

Section 9 provides for maintaining the possessory right of a bona fide claimant of a mining claim located prior to August 28, 1937.

Section 10 reserves "to the Secretary of the Interior the right to grant such easements or rights-of-way including easements in tunnels, upon or through the lands for joint or several use as may be necessary and appropriate to the working of the lands or of other lands containing deposits subject to disposal under this or any other mineral leasing Act,....."

Section 11 requires "the exercise of reasonable diligence, skill and care in the operation of the leased property; the use of the surface of the lands covered by the lease only for purposes incident to mining; and the observance of such rules for the safety and welfare of miners and for the prevention of undue waste as may be prescribed by the Secretary of the Interior."

Other specifications in this section are concerned with conforming to the 8-hour day, prohibiting the employment of minors and women underground, and the twice-a-month pay day. "Each lease shall also contain such provisions as the Secretary of the Interior may deem necessary to insure the sale of the production of such lands to the United States and to the public at reasonable prices, for the protection of the interests of the United States, for the prevention of monopoly, and for the safeguarding of the public welfare." The final provision in this section generously states, "Nothing in this Act shall be construed to affect the right of the State or other local authorities to exercise any rights which they may have with respect to properties leased hereunder, including the right to levy and collect taxes upon improvements, output of mines or other rights, property, or assets of any lessee of the United States."

Section 12 provides that "No lease issued under this Act shall be assigned or sublet, except with the consent of the Secretary." Other parts of this section are in explanation of method prescribed for relinquishing a lease.

Sections 13 and 14 emphasize the complete control of the surface of the ground leased, exercised by the Government. Upon 30 days' notice by the Secretary of the Interior, leases, permits, or rights acquired under this Act affecting lands valuable for power sites may be cancelled and the licensee or permittee shall not be entitled to the payment of any damages or compensation whatsoever or to reimbursement for any financial or property loss caused by such use and development. Likewise, leases, permits or rights acquired under this Act allow no authority to cut, use, or remove timber for any purpose. Timber for mining operations may be cut or removed only as authorized by regulations prescribed by the Secretary of the Interior.

The remaining sections of the proposed bill have to do with disposition of moneys received by the Government from leases and are of no particular interest except as applied to the revested lands involved.

Conclusion:

The United States mining laws having to do with location and maintaining possessory right in mining claims are admittedly open to criticism. In normal times, there have been many instances of persons holding ground by doing only a token of the required amount of work. In addition, work of such a character may be done which entirely satisfies the law but which bears no relation to development of the ground for mining purposes. Anyone who has had any experience in such work knows that annual work on many undeveloped mining claims, even if the law is observed religiously, is usually done wherever the work is easiest or simplest without much regard to developing valuable minerals. One hundred dollars' worth of work on a claim is too insignificant to have much effect in developing a mine, particularly if that amount is used year after year at a place where the object is to get the work done as easily and quickly as possible. If multiples of \$100 could be spent on a group or groups of claims under proper supervision, some good in the way of mineral development might be accomplished. Under conditions obtaining over the past decade, the matter is more or less academic, since mining claims have been exempted so much of the time from annual assessment work. In the future, when the exemption is removed, possibly some modification of the mining laws designed to correct the above-mentioned weaknesses may be feasible. Certainly the answer is not in mineral leasing by the Government.

All national legislation nowadays seems to be aimed at placing more and more power in the hands of the Federal Government. This bill is a good example. It is rather weak technically, but it is decidedly strong in insuring the Secretary's control over the leased land. Apparently no need is felt for encouraging prospecting; only the need for rigid control by the Government of all prospecting activities. No better way can be found to stifle discovery of new ore deposits than such Governmental control.

F.W.L.

ACTIVATED CARBON FROM TEXAS LIGNITE*

Activated carbon has been manufactured from Texas lignite since 1922 at the Darco Corporation plant in Marshall, Texas. Lignite is the principal raw material for making the carbon, although sawdust and charcoal are also used. The plant is well situated with respect to convenient and adequate sources of both the necessary raw materials and natural gas, which is used for fuel.

Most of the lignite in the Coastal Plain region of Texas is of suitable quality for making activated carbon, with the exception that in some deposits sulphur is present in objectionably high quantities. The lignite used in the Darco plant has an average moisture

* Extract from Mineral Resource Circular No. 30 by Glen L. Evans, Bureau of Economic Geology, The University of Texas, Austin.

content of about 31.5 percent. The dried material contains about 11 percent ash, 43.5 percent volatile and combustible matter, and 45.5 percent fixed carbon. The volatile and ash constituents are waste products of the operation. Attention is being given to possibilities of converting the waste into valuable by-products.

The primary steps in the process of making activated carbon consist of (1) burning the lignite in furnaces; (2) acid-water washing the burned product to remove residue; (3) grinding and air classifying; (4) packaging for shipment. In the course of plant treatment the carbon acquires the highly adsorptive properties which makes the finished product an effective filtering agent. The word "activated" is in reference to this adsorptive property. Most of the carbon is marketed in finely powdered form, but some lump material is sold for use in water filtration plants. The powdered grades range from 70 to more than 90 percent minus 300-mesh particles. Surface adsorption area, and consequently the effectiveness, is increased with increasing fineness of the grind.

Domestic and foreign markets have been established for the finished carbon products, and the demand has increased appreciably during the past decade. The carbon is sold under the trade names "Darco" and "Hydrodarco." Hydrodarco is used in water filtering and purification plants to remove suspended matter responsible for undesirable colors, tastes, and odors. Darco is used as an adsorptive medium for decolorizing and purifying various liquids and solutions, including sugars, syrups, edible oils, solvents, chemicals, and pharmaceuticals. An interesting and important application of activated carbon has recently been developed in the manufacture of penicillin. The adsorptive properties of the carbon are utilized to remove the active penicillin ingredients from extremely dilute solutions. The carbon is similarly used in vitamin research. Activated carbon, being an adsorptive agent, does not compete in the markets with carbon black from natural gas which is used almost entirely in rubber goods and pigments.

MINING NEWS FROM GRANT COUNTY, OREGON

In the Murderer's Creek area Bob King and partners have opened up a good showing of high grade chrome ore, and results of analyses on some samples show metallurgical grade. Shipments to the Metals Reserve depot at Seneca will begin soon.

* * * * *

Hugh Campbell and partners have also opened up a promising lens of high grade chrome near the King holdings, and will soon begin shipments to the Government depot.

* * * * *

Ward Mallennex and Irving Hazeltine have commenced operations on the Celebration claim, and shipments will soon be going forward to the Seneca depot. This property has already produced about a thousand tons of ore which averaged 38 percent Cr_2O_3 . It is also understood from these men that the Haggard-New property which produced several hundred tons of high grade ore will be reopened, and a considerable tonnage is expected to be shipped this summer.

* * * * *

No gold properties are operating at this time but considerable interest has recently been shown in possible placer operations. Bert Kumle, who was formerly with the Ferris Gold Dredging Company, and who now owns and operates a dredge in California, was in the district lately testing ground for gold values in order to plan for postwar operations.

STATE DEPARTMENT OF GEOLOGY & MINERAL INDUSTRIES
Head Office: 702 Woodlark Bldg., Portland 5, Oregon

State Governing Board

W. H. Strayer, Chairman	Baker	F. W. Libbey	Director
Niel R. Allen	Grants Pass	John Eliot Allen	Geologist
S. H. Williston	Portland	Esther W. Miller	Ceramic Engineer

State Field Offices

714 E. H Street, Grants Pass	2033 First Street, Baker
W. A. G. Bennett Field Geologist	Norman S. Wagner Field Geologist

MINERAL DISCOVERY HAMSTRUNG IN WESTERN OREGON

Statement of S. H. Williston
 President, Oregon Mining Association
 Member, Board of Governors, Oregon State Dept. of Geology & Min. Ind.
 Before Senate Small Business Committee
 Portland, Oregon
 July 28, 1944

The mining industry in the State of Oregon comes under the category of small business as none of the mines in the State employs in excess of 100 men. The mining industry of the State has had two tasks placed before it. One is the procuring of strategic and critical minerals during the war period. That job has been finished and the State has provided appreciable amounts of strategic and critical minerals for the war effort. The second task for the industry consists of the further development of the mineral industry in the State to aid in providing jobs for returning service men as well as for present employees. It is very probable that this second task cannot be accomplished owing to the action of that branch of the Federal Government to which the United States Congress has given the job of furthering the development of mining in general, namely the Department of the Interior.

In 1916, the Oregon and California land grant and the Coos Bay Wagon Road land grant were cancelled and those lands were returned to the Federal domain. It was explicitly provided at that time that mining claims and mining locations could be made on these lands on exactly the same basis as on other lands in the Federal domain.

In 1937, another bill was passed by Congress providing that these lands were to be turned over to the Department of the Interior, and that the timber on these lands should be so handled and so disposed of that they would yield a continuing crop of timber, in other words, placed on a sustained yield basis. No mention was made in this act of changing the previous authorization providing for location of mining claims upon these lands. On August 12, 1943, during the progress of the war, the Commissioner of Public Lands at the direction of an Assistant Secretary of the Department of the Interior notified all claim owners that all mining claims located on these lands since 1937 were null and void. The basis of this order was that the 1937 act by inference repealed the explicit authorization of the 1916 act as, in the opinion of the Department of the Interior, the location of mining claims would interfere with the sustained timber yield from these revested lands.

Since it is a known fact that mineral deposits of commercial value rarely cover more than one-half of one percent of any given mineralized area, the Department of the Interior was, in effect, stating that if one-half of one percent of the Oregon-California land grant lands were utilized for mining, it would no longer be possible to carry on sustained yield lumber production on the other 99½% of the area.

The O and C lands, together with the Coos Bay Wagon Road lands, cover approximately 33-1/3 percent of the lands west of the Cascades in the State of Oregon. They cover almost 50 percent of the lands in the mineralized districts in Josephine and Jackson Counties. They consist of almost all of the Federal domain lands open to mineral exploration in the southwestern Oregon mineral district.

You will note that this withdrawal of mineral lands for prospecting and mineral location was made in the summer of 1943 when the general outlook in regard to the prosecution of the war was far less promising than it is today. At that time, every effort was being made to expand mineral production in all categories, especially in the strategic and critical minerals most important to the prosecution of the war. It was at this very moment when it was thought that additional mineral supplies were most crucial that the Land Office, at the direction of an Assistant Secretary of the Interior, closed all of these mineral lands to location.

If an individual producer had at this time shut down an operating metal-producing property and had refused to produce additional metal, the action would have been considered treason, and the property would have been confiscated by the Government and operated by the Government. If any labor union had refused to produce mineral necessary for the war effort at this time, public sentiment would have been so overpowering as to force them to withdraw from any such action. Yet at this very instant, a branch of the Department of the Interior withdrew these lands and prohibited prospecting, development, or mining upon them. If it is treason for an individual or treason for a labor organization, what should it be called when ordered by a branch of the Federal Government?

Unless this action of the Land Office, by direction of the Department of the Interior, is altered or unless Senate Bill 1982, introduced by Senator Guy Corden of Oregon is passed, it is going to be impossible for the mining industry to enlarge in any way its activities in Oregon's important southwest mining district. Further, unless the Congress of the United States freezes the Government stockpiles of strategic and critical metals, it will be impossible for any metal mining operations in the State of Oregon, with the exception of gold, to operate at all in the post-war period.

S. 1982

IN THE SENATE OF THE UNITED STATES

June 7 (legislative day, May 9), 1944

Mr. Corden introduced the following bill; which was read twice and referred to the Committee on Public Lands and Surveys

A BILL

To reopen the revested Oregon and California Railroad and reconveyed Coos Bay Wagon Road grant lands to exploration, location, entry, and disposition under the general mining laws.

Be it enacted by the Senate and House of Representatives of the United States of America in Congress assembled, THAT NOTWITHSTANDING ANY PROVISIONS OF THE ACT OF AUGUST 28, 1937 (50 STAT. 874), OR ANY OTHER ACT RELATING TO THE REVESTED OREGON AND CALIFORNIA RAILROAD AND RECONVEYED COOS BAY WAGON ROAD GRANT LANDS, ALL OF SUCH REVESTED OR RECONVEYED LANDS, EXCEPT POWER SITES, SHALL BE OPEN FOR EXPLORATION, LOCATION, ENTRY, AND DISPOSITION UNDER THE MINERAL LAND LAWS OF THE UNITED STATES, AND ALL MINERAL CLAIMS HERETOFORE LOCATED UPON SAID LANDS, IF OTHERWISE VALID UNDER THE MINERAL LAND LAWS OF THE UNITED STATES, ARE HEREBY DECLARED VALID TO THE SAME EXTENT AS IF SUCH LANDS HAD REMAINED OPEN TO EXPLORATION, LOCATION, ENTRY, AND DISPOSITION UNDER SUCH LAWS FROM AUGUST 28, 1937, TO THE DATE OF ENACTMENT OF THIS ACT: PROVIDED, THAT ANY PERSON WHO UNDER SUCH LAWS HAS ENTERED SINCE AUGUST 28, 1937, OR SHALL HEREAFTER ENTER, ANY OF SAID LANDS SHALL NOT ACQUIRE TITLE TO THE

TIMBER THEREON, WHICH TIMBER MAY BE DISPOSED OF AS IS OR MAY BE PROVIDED BY LAW, EXCEPT THAT SUCH PERSON SHALL HAVE THE RIGHT TO USE SO MUCH OF THE TIMBER THEREON AS MAY BE NECESSARY IN THE DEVELOPMENT AND OPERATION OF HIS MINE UNTIL SUCH TIME AS THE TIMBER IS DISPOSED OF BY THE UNITED STATES.

This bill is now before the Senate Committee on Public Lands awaiting Federal departmental reports.

STRATEGIC NOTES

The following items relating to war industries and industrial problems were abstracted from the monthly news letter issued by Joseph Schulein, Secretary of the Oregon Section American Chemical Society.

Arabian Oil:

The government has given up its plans for the construction of the Saudi-Arabian pipe line. Observers believe that the circumstances surrounding Arabian oil are closely allied with international relations, which, together with the usually turbulent political situation in the Middle East, compelled the decision not to undertake the project. If the pipe line across Arabia is to be built it will be financed by private industry and probably operated by the companies that lay it. The government would probably aid when and if asked.

Oil is so important in modern war that much interest has been focused on the Arabian fields (see Fortune for June, 1944). The drain on Western Hemisphere oils has been tremendous. The Saudi-Arabian field is one of the richest ever discovered and is under lease for fifty years to an American company. The proposed pipe line would travel 1250 miles from the Persian Gulf, through Trans-Jordan and through Palestine to Haifa on the Mediterranean where large refining capacity is now established. Cost was estimated at 150 millions.

The construction of such a competing line across the Arabian Peninsula would be a move against the British policy of conserving their own oil and using that of the Western Hemisphere. Construction of the line would make it possible to reduce or even eliminate shipments of Western Hemisphere oil to Europe and the Middle East.

There is no doubt as to oil's importance. Under lend-lease* oil exports from this country may be doubled this year. Petroleum constituted the biggest single item in all of the billions of dollars appropriated for lend-lease. Three-fourths of this will be gasoline. Shipments are to be made to Great Britain, Russia, China, French North Africa, and the Middle East.-- Those who think '100 octane' gasoline is good stuff haven't seen anything yet.-- Most of the gasoline to be sent abroad will be "grade 130."

* * * * *

Shortages:

Among the shortages still bothering are --

Copper sulfate - stock is lowest in last two years.

Manganese sulfate - demand exceeds supply.

Anthraquinone - all going to dyestuff industry, none other available.

Phthalic anhydride - the effectiveness of a new insecticide which is a phthalic derivative will cause a shortage - phthalic anhydride comes from naphthalene, a coke-oven by-product. -- Naphthalene is up to 100 million pounds a year, but that is not enough.

* Since the lend-lease program was inaugurated a total of about 60 thousand-million dollars has been spent or pledged.

Benzaldehyde - very short.

Chrome chemicals - very short.

Fluorspar - 20,000-30,000 tons short this year (will have to import). Most of this is due to labor shortage -- men taken into armed forces. U.S. production (acid grade) about 140,000 tons.

Sodium cyanide - this is critical. You are asked to conserve all supplies.

Alcohol - 650,000,000 gallons needed for rubber and war program -- present capacity is insufficient.

Milk sugar - will probably be curtailed in pharmaceuticals due to the great need in the manufacture of penicillin.

* * * * *

Synthetic Rubber:

All right, so it isn't really rubber - but the public wants it to be synthetic rubber and we think the popular name will stick. Anyway, it is going to be a big factor in international relations and will get kicked around plenty - politically of course. Because natural rubber has always been big business, many have wondered what would happen when its bouncing baby grew up, now it is bigger than papa and every month helps it grow, each month makes it harder for natural rubber to regain its previous position. As chemists we've all been interested in the technical advances made by synthetic - The future, however, will be determined by the economics - the truth is that synthetic is cheap - The Rubber Director has set the postwar cost of GR-S (BUNA-S) made from petroleum butadiene, at 13.05* cents per pound, including depreciation; if the plants are written off as war plants (which is highly probable) GR-S will be about 12 cents. Therein lies the political implications.

It was British enterprise that initiated rubber planting in the far east, and British capital, followed by Dutch, laid the foundations for the industry, consequently the future of rubber is intensely interesting to Britain.

The British Rubber Growers' Association is a strong organization and is actively at work to protect the long-term interests of rubber producers, they are, of course, banking heavily on the fact that in Britain it is considered good Government to support British business first.

Factually, three important factors are facing the growers -1, Staff-trained European Supervisors have been dispersed, many will not want to gamble a future in natural rubber again. -2, Labor. As far as Malaya is concerned, none of the native labor was indigenous to the country. The Chinese there will have fared badly at the hands of the Japs, as will have the Tamils, they will probably want to be repatriated - (Ceylon, which produced over 8 million pounds of rubber this past year, had to resort to growing rice for food due to restricted imports) -- those who take their places will have been awakened to the idea of a better living, (though to give credit it must be admitted that the British had improved native conditions, pioneering in estate health and sanitation, and the elimination of malaria and other tropical diseases). Labor costs will be up. -3, Material. The technical developments of the war will probably mean that the form in which rubber is marketed (crude) will be changed - and all the above is still dependent on how much irretrievable damage the Japs do as they are forced out.

*Pre-war natural rubber could be produced for 6½-7¢ per pound, making the delivery price in U.S. around 9¢. In early 1920's crude hit a disastrous low of 3¢ at which time the British Government put it under cartel control (Stevenson plan), by mismanagement set a "fair" crude price at 30 cents, raised it to 36, and finally let it boom to \$1.21, thereby giving the search for synthetic a boost and putting American interests (Firestone, Ford) in the rubber plantation business.

This month, the "Baby" stopped growing so fast, the Rubber director diverted 400,000 barrels of Petroleum butylene from the Synthetic Rubber Program to the manufacture of aviation gasoline, this is enough, when added to ethyl benzene, for around 1,000,000 barrels of 100 octane, (about 30,000 tons of Buna-S will be sacrificed) - While we're on the gasoline subject - a flying fortress uses 235 gallons per hour - About 1 gallon per day per car has been earmarked for passenger use - 11.7 percent of the daily petroleum supply. Production of butadiene from petroleum still lags -- Plants using alcohol butadiene are running ahead of rated capacity, with Buna-S total amounting to more than 700,000 long tons per year.

Of course, synthetic and natural are not the same in many respects - some of the characteristics of synthetic are actually detrimental. More labor is required in processing a synthetic tire than one of the natural rubber - Dirt raises heck with quality and so more care is needed - where crude could be mixed in 18 minutes for inner tubes, synthetic takes 25 - and also takes longer to mold cure. Synthetic requires more capital for the same capacity - reclamation of used crude-synthetic mixtures has not yet been completely solved.

The Rubber business in the U.S. is mainly handled by the big 4, Goodyear, Firestone, U.S., and Goodrich, (in order of sales) who make over 80% of the tires and use about two-thirds of the rubber. Goodyear owns Kelly-Springfield; U.S. owns Fisk, Federal, and Gillette; Goodrich owns Hood, Diamond, Brunswick, and Miller.

Goodrich's President, John Collyer, estimates that post-war requirements of the U.S. will be at the rate of 900,000 tons a year, and of the world, 1,600,000 tons. World synthetic capacity will be about 1,200,000 tons, indicating a need for approximately 500,000 tons of natural, this 1,200,000 tons capacity is based on what the Russians are scheduled to set up, whether they will stop at their schedule or not remains to be seen. They have now been given the Neoprene "know-how" by order of the American Government, obviously this would not have been done without some regulation in the future as to capacity - in effect then, the U.S. Government is now running, and will continue, a rubber "cartel."

CHROME CHEMICALS DISCUSSED

The War Production Board issued the following release August 5, 1944. Why Oregon chrome from chromite sands was not included in discussions along with Montana chrome is not clear.

Use of Turkish, Russian, Canadian, and domestic Montana ores, if ample supplies of Transvaal ores are not imported from South Africa for the production of primary chromium chemicals, was discussed recently by the Primary Chromium Chemical Producers Industry Advisory Committee, the War Production Board reported today.

Transvaal ores, now used exclusively for primary chromium chemical production, may not be available in adequate quantity during the coming months, because of lack of space on ships, committee members said.

Production problems due to the varied ore content and price readjustments requiring additional subsidies are the obstacles that probably would be encountered in a switch to the alternate ores, the committee pointed out. Each producer of primary chromium chemicals has agreed to investigate production problems that might arise from use of these ores in the individual plants and to submit a report to WPB.

In an effort to combat production bottlenecks, the Chemicals Bureau has arranged for the installation of improved equipment in many plants. More efficient production technique is expected to boost the output of primary chromium chemicals 10 percent in 1945, officials said.

Five of the six existing primary chromium chemical producing plants have arranged to use the higher chrome content Russian ore to augment production during the summer months when production declines because of hot weather, Chemicals Bureau officials told the Committee. It is hoped, they said, that the output of primary chromium chemicals would be maintained at a rate sufficient to permit the continuance of allocations similar to those during the past three months.

Military applications, comprising approximately 87 percent of the primary chromium chemicals produced in this country, include use in the manufacture of pigments for camouflage, in the tanning of military leather, and in the plating and anodizing operations for aircraft production. The remainder of the output is reserved for civilian needs, such as for the tanning of leather for shoes, the production of pigments, and the dyeing of textiles for men's suits.

DOC YAK

The following true story of an old prospector and neighbor is related by R. F. Stout, C.T.M., U.S.N. (Ret.), Naval Torpedo Station, Newport, R.I. "His nickname was 'Doc Yak' and he was an old prospector with his last home in Wilbur, Oregon. I first met him in June 1934 when I had a few days leave from Keyport, Washington, to go fishing and look around for a home site when I retired from the Navy. So I asked in the corner store and filling station if any one of their friends wished to sell their home as I was a prospective neighbor. There were but two men in the store, Duffy and Cat. I was a stranger in uniform, so they looked at each other and smiled with that understanding which only friends possess. They said, 'Yes, our friend Doc Yak has just what you are looking for. They both proceeded to direct me to his place which was only about five blocks away. So I walked over to his place and from a distance the house looked O.K. As I got closer I noticed a tall lanky man forking out hay in the door of the barn and he was just giving a goat the bum's rush with the pitch fork. As I approached him I greeted Doc with a good afternoon and gave him 'the once over.' This is the way he was dressed: An old sloppy hat with a hole in the rim, a shirt of unknown color, a pair of pants that were slick with grease and dirt, one shoe, no lace, one rubber boot with the top out off. His hair was long and his neck very dirty but shaved with a high tide mark on jaws and neck. Doc had a habit of first sitting on the ground and then lying down; he did this while I was talking to him. After a few minutes I stated why I was there, and he said, 'I will show you the house.' We walked up to the kitchen door which was wide open. It looked as if the door was never closed. With Doc in the lead and me astern we stepped into the kitchen. In one corner there was an old rusty broken-down stove with a rock under one corner to hold it up. On the stove were a skillet and pans, and their interior contained enough odds and ends to make a Chinese ten course dinner by adding a little water. On the shelf there was a sour dough jar. The place was covered with dead flies and cobwebs from the kitchen to the bedroom. There weren't any slats in the bedstead frame, and the bedding on the floor looked like a ground hog hole. The Bantam chickens had roosted on the bedstead and the chair backs; of course the goats had the run of the house. One could have planted garden seeds on the floors and by adding water it would have been a very fertile garden patch. In the front room on the stairway railing there was an old rotten deer hide; also the room had an old rocking chair with a deer hide bottom. Well, during the tour of inspection I tried to hold my breath and walked fast to get outside to the fresh air once more. I thanked Doc and left wishing that I had a drink to settle my stomach. Eventually I did buy a home in Wilbur and moved there in 1937. That same year Old Doc passed away. His neighbors still blame them at the County Home for Doc's sudden departure from among us. As the story goes the doctor ordered a bath which proved fatal. But before Doc passed on he told the nurse that he had a sum of money buried in the garage under an old 1914 Model T Ford which was jacked up on blocks. It had a 1923 California license. So a treasure hunt was organized at once and we dug up fruit jars which contained \$1900.00 in bills and coins. One of the party said, 'Gentlemen, that is Doc's soap money which he saved over a period of 60 or 70 years.'"

STATE DEPARTMENT OF GEOLOGY & MINERAL INDUSTRIES
Head Office: 702 Woodlark Bldg., Portland 5, Oregon

State Governing Board

W. H. Strayer, Chairman	Baker	F. W. Libbey	Director
Niel R. Allen	Grants Pass	John Eliot Allen	Geologist
S. H. Williston	Portland	Esther W. Miller	Ceramic Engineer

State Field Offices

714 E. H Street, Grants Pass	2033 First Street, Baker
W. A. G. Bennett Field Geologist	Norman S. Wagner, Field Geologist

WESTERN STATES MINING CONFERENCE

On August 10 and 11 delegates appointed by the governors of the eleven western states and South Dakota met in San Francisco at the request of Governors Carville of Nevada and Warren of California to consider problems facing the mining industry and to make recommendations. A report of the proceedings of the conference has been issued. Governors Carville and Warren, both of whom addressed the conference, stated (quoting from the report) ". . .that the principal motive in calling the conference had been to ascertain whether any changes in the existing laws and regulations affecting mining should be made, and whether any new laws were necessary, in order to enable the mining industry to do its full part in the reconversion of the Nation from war to peace, and in making available the maximum economic employment of men in the mining industry."

Space does not permit quoting the complete report. All of the recommendations made are of importance to Oregon, but those which are perhaps of most concern to this state are reproduced below.

The Production and Marketing of Gold

War Production Board Order L-208:

In the opinion of this Conference, War Production Board Order L-208, singling out gold mining as the sole American industry to be closed down during the war by government order, never was justified. Incontrovertible facts showing such lack of justification were available to and should have been known by the War Production Board at the time the order was promulgated. The order never accomplished its stated purpose of diverting man-power and materials into strategic metal mines. The needs of postwar employment require that jobs be available in the gold mines and dredging operations so soon as the man-power shortage ceases. In order to enable mine operators to prepare for resumption of operations, Order L-208 should be rescinded now and, pending the effective date of such rescission, the War Production Board should adopt a liberal policy of permitting individual mines to produce enough gold bullion to return their maintenance costs.

Gold mining not a non-essential industry:

The practice of constantly referring to the gold mining industry as a "non-essential industry" which for some time has been and still is currently emphasized in bulletins, press-releases, directives, and regulations issued by the War Production Board, War Manpower Commission, and Office of Price Administration, casts an unjust reflection on an industry which furnishes the sole important source of peace-time employment and major source of local business in over 19 counties in California, practically all the counties of Nevada, Idaho, and Colorado and important parts of Oregon, Washington, Utah, Arizona, Montana, South Dakota, New Mexico, and Wyoming. Without desiring to detract or draw from

man-power or materials actually used or useful in the war effort, we demand that these government agencies cease this unjust discrimination against our industry as compared with other peace-time industries who serve no more useful purposes in war time, and accord us our fair share of labor certifications and material priorities necessary to permit operation under existing limitations of Order L-208.

Foreign markets for gold:

It is currently reported that the free market price for gold in India, North Africa, and Asia Minor has fluctuated between \$40 and \$80 per ounce, and that mines in the British Dominions are enjoying that price for their product; and this meeting of mining representatives from the Western mining States believes that restoration of the ability of American gold mines to produce gold at the earliest moment consistent with war man-power demands, is essential to the preservation of the local economies of the districts in which they are located, to postwar employment opportunities for miners and prospectors, to the maintenance of an adequate national currency backing of gold, and to the stabilization of international money exchanges on a basis that will permit of the free resumption of international trade after the war. We believe that the President and through him, the Secretary of State of the United States should be memorialized to take such steps and enter into such negotiations as will make free markets for gold in foreign countries available to American gold producers, and will remove current legal restrictions on the export of newly mined gold to such markets by American producers.

Monetary Policy

We advocate the use of gold and silver in the International Fund and also in the International Bank, proposed at the Bretton Woods Conference of 44 nations or in any other International Monetary Program. We believe that the American people are in favor of a sound monetary system, safeguarding their interests against paper inflation. Printing press currency is not desired by the average American, nor does he want the currency of the United States debased by any international group of "experts."

Experience of the world with greenbacks after the Civil War, and with worthless German marks after World War I, was disastrous and caused a lack of confidence in any "managed currency" plan.

Stockpiling

It is imperative to the continuation of the mining and smelting industry and postwar employment of the maximum number of employees possible, that (1) all government owned stockpiles of strategic or critical metals and minerals and all government owned or controlled nonferrous scrap metal shall be frozen at the termination of European hostilities, and that (2) all reverse lend lease and preclusive purchases of metals and minerals should be added to such frozen stockpiles, as failure to do so means the stagnation of the mining industry of the United States.

These reserves of critical or strategic metals and minerals should be kept inviolate for future war emergencies and must not be released except by Act of Congress.

Taxation

Drastic alteration in the Federal tax laws and their administration is essential to the development of new mines and to the maintenance of production and employment in existing mines at a satisfactory level.

Prompt revision of the Federal income tax laws must follow the conclusion of hostilities. Otherwise, a speedy and orderly return to a productive and stable peacetime economy based upon American principles of free enterprise will be impossible. The

necessity for large revenues will continue after the war and the mining industry recognizes its obligation to bear its fair share of the necessary costs of servicing the national debt and of efficient and economical administration of the government. These costs can be met and the Federal budget balanced only if taxes are imposed for the sole purpose of providing revenue and are levied in such a manner as to preserve individual incentive and encourage the investment of risk capital in the production of new wealth and the expansion of employment. Only in this way can the American standard of living be maintained and improved and national solvency be assured.

The excess profits tax must be quickly repealed upon the termination of the war. This tax penalizes efficiency, deadens incentive, and imposes an arbitrary ceiling upon the rewards of productive effort which, if continued into peace time, will do mortal injury to our system of free private enterprise.

Other corporate taxes should be reduced as much as fiscal necessities will permit and so simplified as to eliminate the burden of multiple returns and reports. The capital stock tax and related declared-value excess profits tax should be repealed. The crushing discrimination against business corporations worked by existing tax laws must be removed. The present unjust double taxation of corporate earnings should be ameliorated by some system of credits or by the partial exemption of corporate dividends, in order that shareholders of corporations, whether large or small, may be permitted to receive a fair share of corporate profits.

The taxation of capital gains at high rates and arbitrary limitations on the deduction of capital losses effectively discourage the investment of risk capital in new enterprises. This is especially true in mining enterprises in which the hazards of loss are great. A ceiling rate of not more than 15 percent should be provided in the case of long-term capital gains and arbitrary limitations upon capital losses should be removed.

Adequate allowances for depletion are essential to the preservation of a sound and dynamic mining industry. Such allowances, including percentage depletion, should be preserved in any revision of the tax laws. The administrative simplicity of the percentage method of depletion is seriously threatened by hypertechnical administrative interpretations and procedures, the apparent tendency and purpose of which is the reduction of the depletion base. Wherever necessary, clarifying legislation, such as the recent amendment defining gross income from the property, should be enacted to nullify arbitrary bureaucratic action in derogation of legislative policy and intent.

Section 122 of the Internal Revenue Code, relating to the net operating loss, should be amended so as to eliminate certain limitations which work serious and invidious discrimination against the natural resource industries.

The present opportunistic administrative policy of retroactive revision of rates of depreciation is unfair and disturbing to the fiscal stability of industry and should be revised.

The present policies and procedures of the Bureau of Internal Revenue in the administration of claims for relief under Section 722 of the Internal Revenue Code are antagonistic to the spirit and purposes of this equitable provision and should be drastically modified. Elaborate instructions which have been given to field agents to guide them in the processing of these claims should be published and thereby be made to run the gauntlet of free criticism.

All internal revenue directives and instructions to field agents as to policies to be followed in disposing of taxpayers' cases should be made public.

Public Land Policy

This Conference strongly disapproves the reported policy of the General Land Office in initiating proceedings to have mining locations held void for lack of discovery, where they are made on the unreserved public domain by locators who believed in good faith that they contain valuable metals in mineable quantities and have been prevented by war temporarily or other conditions from perfecting their discoveries. The Taylor Grazing Act should be amended to prohibit the initiation of such contests by the General Land Office for the benefit of grazing land lessees, and the latter should be relegated to the courts for protection if they believe their rights have been infringed by mineral locators.

We condemn without reservation the arbitrary and illegal withdrawal by executive order of vast areas of the public domain from universal entry, by various divisions of the Department of the Interior. Such action prohibits the development of new mines and destroys all possibility of increased employment in the industry. We oppose the provisions of U.S. Senate Bill 736 and any other bill introduced or that may be introduced containing similar provisions or objectives.

Disposal of Basic Defense Plants

We favor an orderly transition from Government ownership to private ownership and operation for all present Government-owned "war plants," but only on a sound economic basis; and that this process or changeover be done in such a way and at such a time as not to interfere with national security.

We urge that before a plant is shut down or its production curtailed prior to ultimate sale or disposal, due consideration should be given, insofar as possible, to the overall economics of such change; that such change be made, when possible, only after a thorough-going survey by competent disinterested, nonsectional, non-political engineers and specialists.

We favor outright sales of such war plants to private industry whenever they can be made in harmony with public welfare. Plants and equipment of potential postwar value which may be found to be unsalable in the immediate postwar period, except at sacrifice prices, should be leased for private operation until economic conditions governing their ultimate actual value can be determined. Leases should be made with the objective of putting the facilities into useful operation and as a means of testing the market for the product. Leasing policies may also be employed to keep in working condition those plants which may be needed in future military programs.

BEARING ON OWNERSHIP OF OUR "USELESS" GOLD STOCKS AT FORT KNOX

The following is an extract from the monthly news letter of the Oregon Section of the American Chemical Society:

Let's look at the poor foreign countries our commissions will now save (by restrictions on U. S. business, of course).

Since this country entered the war, other countries have added \$6,350,000,000 to their gold and short-term dollar resources. Many do not realize how our war expenditures help do this. When we entered the war, the total monetary gold stocks of the rest of the world were about \$8,750,000,000, of which about $\frac{1}{4}$ was held under ear-mark in this country. It is estimated (conservatively) that another \$2,000,000,000 gold was held in government and central bank accounts. With the \$3,500,000,000 of foreign-owned bank deposits and investments (short-term) the total foreign gold and dollars were in excess of \$14,000,000,000.

To this should be added \$3,000,000,000 in foreign held U. S. stocks and bonds and \$3,500,000,000 in direct investments.

As the war proceeded, payments to foreign countries rose. Strategic material imports increased greatly. We paid cash for these. During this time our cash exports have fallen way off (Lend-Lease going up). Thus our cash trade balance turned against us. Our troops in Australia spend \$200,000,000 a year for goods and services over and above reciprocal lend-lease. During the North African campaign, we spent in excess of \$400,000,000 in Egypt alone. These payments to foreigners have piled up - we have not had goods to sell them - they get them free under Lend-Lease. Add to this the decrease in our gold production and the decline in U. S. gold stocks, and the end of this year will see foreign-owned gold and dollar balances hit the \$22,000,000,000 mark - about double the total world gold stocks 10 years ago.

In 1919, at the end of the 1st World War, the foreign total was only about \$5,000,000,000. Now our economists are telling us that we must continue lend-lease to Great Britain after the war with Germany is over. The annual cost would only be a trifling \$2,500,000,000 over and above war costs (\$78 per average family). Reasons - normally the Kingdom imported about \$4,000,000,000 worth of goods each year (62% food-stuffs). This was paid for by foreign investments - \$800,000,000; shipping, \$500,000,000; exports, \$2,500,000,000; balance by miscellaneous, services (insurance, etc.). With declining exports Great Britain visualizes that she will be short \$2,500,000,000 of balancing this "economy", and that's where we come in. They don't want a loan - they want lend lease.

Not counted by these same "economists" is the fact that due to our past lend lease our own debt has skyrocketed while Great Britain has been able to keep hers down to \$70,000,000,000. Now repeat the above for all the other countries and answer the \$64 question: When all the International Economic Commissions start to regulate U. S. production downward (otherwise there is no reason for their existence) how are we going to save the Brave New World?

ALUMINUM DUST TREATMENT FOR SILICOSIS

According to ROCK PRODUCTS, August 1944, interesting results on the use of aluminum dust as an inhalant treatment of silicosis have been published by the Canadian Medical Association.

McIntyre Research, Ltd., a subsidiary of McIntyre Mines, has been experimenting with preventives and treatments for silicosis for many years. In 1939 this company's research showed much promise in the use of aluminum dust, and intensive testing among the employees of its gold mine at Timmins, Ontario, was begun. According to a recent report in the Canadian Medical Association Journal, the research scientists state that their treatment appears to be followed by beneficial results in a significant proportion of cases.

The treatment used at the McIntyre mine consists of inhalation of aluminum powder. This material is produced by pounding small pieces of thin aluminum sheets into a fine dust, according to a process worked out at the Pittsburgh plant of the Aluminum Company of America. When the aluminum powder is inhaled, the reaction in the lungs coats silica particles with a thin gelatinous film, inhibiting the serious effect of silica on the respiratory organs.

The McIntyre experiments upon 41 men, of whom 34 completed the treatment, consisted of starting the subjects with a five-minute inhalation of the powder. The dosage was stepped up to thirty minutes and the treatments were continued over a period of nearly a year in some cases. At the end of the treatment period, 19 out of 34 men showed clinical improvement, evidenced by either disappearance or appreciable lessening of shortness of breath,

coughing, chest pains, and fatigue. Fifteen of the cases showed neither improvement nor deteriorations and in these cases the subjects had continued work in silica dust, and for this reason results of the tests on these men were considered notable by doctors. Other silicosis subjects under observation who did not take the aluminum dust treatment showed progression of the disease in six of nine cases.

Testing was undertaken at Washington, Pennsylvania, on subjects working in brick-making and refractory plants, foundries, rock quarries, and sand-blasting jobs. Thirty-three cases suffering from silicosis and who had been exposed to concentrations of 17% to 97% free silica all showed improvement in 135 serious cases. Six of the group were unchanged and two became worse. In less serious cases, comparable beneficial results followed the treatment.

MERCURY IN JULY 1944

The U. S. Bureau of Mines in its monthly mercury report No. 60 released September 2, 1944 gives the following statistics on mercury production for July 1944:

The downtrend in mercury production continued in July and the total for the month was the smallest recorded since April 1940. Consumption resumed the decline that was in progress before June and was smaller than in any other month since February 1942. At the end of July, probably principally because of the favorable market relationship between production and consumption in both June and July, the price reacted from the prolonged drop that began at the end of September 1943 and became precipitate in January 1944. In July mercury was removed from the list of materials that are subject to the restrictions of General Import Order M-63.

The production data for July are calculated on reports covering 63 mines that accounted for 97 percent of the total for 1943. Only 21 of these mines were productive in July and 5 of them accounted for 75 percent of the total for that month. Four of the mines are in California and one in Oregon.

Salient statistics on mercury in the United States in 1939-43 and in January-July 1944, in flasks of 76 pounds each

Period	Production	Consumption	Stocks at end of period		Price per flask at New York
			Consumers and dealers <u>1/</u>	Producers <u>2/</u>	
Average Monthly					
1939. . . .	1,553	<u>3/</u> 1,742	12,600	376	\$ 103.94
1940. . . .	3,148	2,233	14,100	607	176.87
1941. . . .	3,743	3,733	12,400	439	185.02
1942. . . .	4,237	4,142	10,700	1,377	196.35
1943. . . .	<u>4/</u> 4,327	4,542	13,200	3,457	195.21
Monthly					
1944:					
January .	4,400	3,400	11,300	5,459	151.60
February.	3,800	3,700	9,400	5,450	130.00
March . .	3,800	3,600	9,900	5,011	130.00
April . .	3,700	3,200	9,700	5,604	128.20
May . . .	3,400	3,100	8,900	6,171	115.54
June . . .	3,000	3,400	9,000	5,757	101.69
July . . .	2,700	3,000	9,300	4,129	100.56

1/ Largely excludes red-stilled metal. 2/ Held by reporting companies. 3/ Apparent consumption. 4/ Based on final figures.

STATE DEPARTMENT OF GEOLOGY & MINERAL INDUSTRIES
Head Office: 702 Woodlark Bldg., Portland 5, Oregon

State Governing Board

W. H. Strayer, Chairman	Baker	F. W. Libbey	Director
Niel R. Allen	Grants Pass	John Eliot Allen	Geologist
S. H. Williston	Portland	Esther W. Miller	Ceramic Engineer

State Field Offices

714 E. H Street, Grants Pass	2033 First Street, Baker
Elton A. Youngberg, Field Geologist	Norman S. Wagner, Field Geologist

NORTHWEST SOURCE OF ALUMINA VITAL

by

Mason L. Bingham
Vice-President, Columbia Metals Corporation

One of the basic problems to be solved if the Northwest is to retain a light metals industry is a competitive source of alumina. As most people know, plants for the production of aluminum metal in this country use, as a raw material, alumina (aluminum oxide) produced from high-grade bauxite by means of the Bayer process. The aluminum plants in the Northwest must, under present conditions, transport alumina across the country from these Bayer plants located in the east.

With the coming of the submarine war and the shortage of other transportation, attention was turned to the utmost utilization of domestic sources of bauxite. The result has been the virtual exhaustion of our domestic resources of bauxite suitable for treatment by the Bayer process. This has left us in the position of depending on overseas transport for bauxite. The alternative is to develop and apply processes to extract alumina from high silica bauxite or high alumina clays.

If the Northwest is to depend on bauxite, then of necessity a dependable source must be controlled. In this hemisphere, the principal known deposits are in Dutch and British Guiana. For a number of years, bauxite has been transported across the Caribbean and treated in this country to produce alumina. Submarine sinkings brought home forcibly the extreme hazard of depending on foreign bauxite for production of aluminum in time of war.

Another question that arises is the economy of transporting bauxite to a Bayer plant located on tidewater in the Northwest. If high-grade bauxite is to be so transported, it would appear to be expedient to look for sources in the Pacific rather than to depend on those in the Caribbean area. It was reported before the war that a substantial deposit (or deposits) of high-grade bauxite was known to occur in the Carolina Islands, and was operated by the Japanese. Inasmuch as Japan still controls a portion of these islands (August 1944), some time may elapse before this source of bauxite may be evaluated in relation to a Bayer plant located in the Northwest. Other possible sources are in the Dutch East Indies. Before the war, high-grade bauxite was mined at Bintan Island near Singapore and shipped to Japan.

It appears from the above that, if the aluminum reduction plants are to be operated economically in the Northwest and with national security in mind, other possible sources of supply are of first importance and should be investigated.

It is known that there are substantial deposits of aluminous clay in the states of Oregon, Washington, and Idaho. These have been explored and drilled to a limited extent by the U.S. Bureau of Mines and the three state mining departments. A substantial tonnage, estimated to be more than 100 million tons, is indicated. The average available alumina content is about 30 percent. However, the economics of the deposits and the metallurgical problems involved have not been fully explored. In furtherance of determining these factors, the Defense Plant Corporation is building a clay treatment plant at Salem, Oregon. The size of the plant is such as to preclude a commercial operation, but it is expected to show whether or not these clays can be treated economically. Allowing for the difference in available alumina as between clay and high-grade bauxite, it is estimated that a delivered price of clay at the plant of \$3.50 to \$4.50 per short ton would be competitive. In addition, there is the possibility of developing by-products that might increase the operating profit.

It is apparent that, if this process proves economic, the benefit to local areas would be much greater than if bauxite were mined abroad and merely treated at a Northwest tidewater plant. It is estimated that about 75% per ton of the cost of clay would go for direct labor in mining and transportation. An additional reason for the furtherance of clay developments is that of national defense. It is hardly likely that this country will ever again depend entirely on overseas shipment for supplies of such vital materials as aluminum and rubber if it can be avoided.

With the concentration of the aircraft industry on the Pacific Coast, an uninterrupted supply of raw material is vital. Prudence would therefore urge that a domestic source of alumina be developed, and the aluminous clays of the Northwest seem to be one likely source of raw material.

A third source of alumina is a deposit of bauxitic iron ore that occurs in northern Washington County, Oregon. The favorable area is included in approximately four townships. There has been some preliminary drilling done on these deposits by the Oregon Department of Geology and Mineral Industries, and results are described in a preliminary report recently published. In only one locality, where most of the drilling has been done so far, a deposit in excess of 2 million long tons of ore is indicated. A typical sample shows approximately 25 percent iron, 33 percent alumina, 10 percent silica, 3.5 percent titania, and 0.15 percent phosphorus.

The Oregon Department's report states that the deposits so far examined indicate that surface mining methods would be applicable, and that such operations would have a stripping ratio generally of not more than 2:1. The overburden is silt and could be easily handled. The ore itself is generally friable, and mining and crushing to the size required for smelting could be done cheaply. Apparently much of the ore so far explored would require no blasting. The average thickness of the ore, which is in flat-lying blanket deposits, is about 11 or 12 feet. The alumina content appears to be fairly constant for each deposit. However, in one area incompletely explored so far, the alumina appears to be considerably better than average and analyses indicate a grade of about 45 percent, with about 18 percent iron and 7 percent silica.

The Pedersen process has been used in Norway to treat material similar to Washington County ore. The U.S. Bureau of Mines has done considerable research work on treatment of siliceous and ferruginous bauxites using adaptations of the Pedersen process. The smelting operation is preferably carried out in an electric furnace, and power consumption is reported to be approximately 3600 kw-hr. per ton of iron produced. One very favorable factor in connection with commercial possibilities of the Washington County ores is the availability of low cost Bonneville power.

The economic possibilities of this ore arise from the fact that it can be treated to produce high-grade pig iron as a primary product, with a by-product of calcium aluminate slag. There is a steady demand for high-grade pig iron in the states of Oregon and Washington. The prewar price of pig iron, f.o.b. San Francisco, was \$23 per short ton.

If a price of \$20 per short ton f.o.b. Portland could be realized, it is estimated that alumina could be produced from the slag at a profit, and at a price less than \$35 per ton f.o.b. Portland, Oregon. It is believed that this alumina would be competitive, both as to price and grade, with that produced from bauxite. There is a further possibility of producing a quick setting cement from the slag. Further drilling in this area is being done by the Oregon Department. A minimum of 10 to 15 million long tons should be assured before an economic operation could be planned.

In the development of all or any of the above-mentioned sources of raw material, careful studies should be made of the economic basis of the metallurgical problems involved. In this connection, it is pointed out that the U.S. Bureau of Mines is about to open an electrometallurgical laboratory at Albany, Oregon. Also the State of Washington has done extensive research on light metals at Pullman. Both these laboratories should be used to their fullest extent in determining which source of alumina would be most economic.

The Pacific Northwest Light Metals Committee, representing Idaho, Oregon, and Washington, was organized to promote the light metals industry in the Pacific Northwest. As it seems essential to a strong industry to have a Northwest source of alumina, the committee could well undertake the following activities:

- (1) Determine the source and availability of bauxite deposits and economic location of a Bayer process plant on tidewaters.
- (2) Obtain the assistance of the mining departments of the three northwest states and the U.S. Bureau of Mines in determining the most economic deposit of high alumina clay containing at least 30 million tons.
- (3) Apply the same investigation to the bauxitic iron ore in Oregon with particular determination as to the market for pig iron in the Northwest.
- (4) Enlist the cooperation of the U.S. Bureau of Mines through the delegations in Congress for laboratory testing and research on the raw materials problem.
- (5) Coordinate the work of the state mining departments in location of workable deposits of raw materials.

It is believed that, if the committee and other interested agencies and groups operate along the lines indicated, a definite basis for economic production of alumina in the Northwest could be established.

Once a source of cheap raw material is assured there is little doubt, with the cheap power available, that Northwest reduction plants would be able to produce pig aluminum at a price competitive with any other plant in the United States.

OREGON MINERAL PRODUCTION

The U.S. Bureau of Mines reports that Oregon mineral production in 1943 was valued at \$12,310,000, and that Oregon was second among the states in mercury and diatomite production and third in antimony ore and chromite. Other metallic minerals produced were gold, copper, manganese, and silver.

Value of metallic mineral production was \$1,346,000; nonmetallics including sand and gravel, cement, and stone were valued at \$10,964,000.

Oregon's total mineral production since 1911 has exceeded \$200,000,000 in value.

QUICKSILVER PRODUCTION

The U.S. Bureau of Mines monthly mercury report for August 1944 released October 5, 1944, gives the following information:

A further decline of 200 flasks in production of mercury in August was accompanied by a sharp rise of 900 flasks in consumption and as a consequence, consumption exceeded domestic production by 1,400 flasks. Of the total output of 2,500 flasks, 7 mines contributed 87 percent. Of these mines, the Abbott, New Idria, New Almaden, Mt. Jackson, and Reed are in California; the Cordero is in Nevada; and the Bonanza in Oregon. The consumption excess affected producers' stocks chiefly and they dropped from over 4,000 to less than 2,300 flasks during the month.

Salient statistics on mercury in the United States in 1939-43 and in January-August 1944, in flasks of 76 pounds each

Period	Production	Consumption	Stocks at end of period		Price per flask at New York
			Consumers and dealers <u>1/</u>	Producers <u>2/</u>	
Average Monthly					
1939 . . .	1,553	<u>3/</u> 1,742	12,600	376	\$ 103.94
1940 . . .	3,148	2,233	14,100	607	176.87
1941 . . .	3,743	3,733	12,400	439	185.02
1942 . . .	4,237	4,142	10,700	1,377	196.35
1943 . . .	<u>4/</u> 4,327	4,542	13,200	3,457	195.21
Monthly					
1944:					
January	4,400	3,400	11,300	5,459	151.60
February	3,800	3,700	9,400	5,450	130.00
March	3,800	3,600	9,900	5,011	130.00
April	3,700	3,200	9,700	5,604	128.20
May	3,400	3,100	8,900	6,171	115.54
June	3,000	3,400	9,000	5,757	101.69
July	2,700	3,000	9,300	<u>5/</u> 4,025	100.56
August	2,500	3,900	9,100	2,252	104.04

1/ Largely excludes redistilled metal. 2/ Held by reporting companies. 3/ Apparent consumption. 4/ Based on final figures. 5/ Revised.

MINERALS NEEDED

The Foote Mineral-Co., Philadelphia, large dealer in minerals, is interested in purchasing the following on a commercial scale:

Dumortierite	Spessartite	Rhodochrosite
Andalusite	Beryl	Wollastonite
Topaz	Brucite	Rutile
Tourmaline	Staurolite	Zircon
Gadolinite	Titanite	Lepidolite
Columbo-Tantalite	Perovskite	Amblygonite
Schorlomite	Rhodonite	Spodumene

THE PIONEERS

(As related by G. F. McDougall)

When the West was young, two chums started towards the setting sun together. Though not related, both had the same surname and given name; but one being slightly larger than the other was known as "Big John" and his partner as "Little John."

Big and Little John finally reached an attractive spot on the Missouri, now the site of an important city, and recognizing its potentialities filed on the vacant land, afterwards accumulating more land until they had a sizeable piece. Since it was on one of the main trails, they soon established a trading post, and a small town arose almost as by rubbing Aladdin's lamp. The partners had land, cattle, and a large safe filled with gold. One partner was mayor and the other school director, a recently created office demanded by the growth of the settlement.

Sending to St. Louis, they were greatly pleased one day when the steamer discharged the new school-teacher, a very attractive young lady, who was immediately installed in the school that had been built, and in suitable lodgings. Frequent after-school journeys to the combined postoffice and store for mail, and to confer with the school director brought her into frequent contact with the two Johns, who promptly fell in love with her. The girl showed no preference, but quite evidently she couldn't marry both so there the matter stood, with the former complete trust and comradeship between Big and Little John worsening every day until finally a bitter quarrel resulted.

One said to the other, "It's Virginia that is at the bottom of this and I'll tell you what I'll do; we'll play a ten-point game of euchre. The loser can lead a lead horse with whatever he chooses, take \$2,000 in gold and his rifle and blankets on a saddle horse, ride out of town and never come back." The other agreed; referees were appointed; others volunteered, and the game started. It was played with great caution, and chance decreed that finally one player had eight points and the other had nine. On playing the next hand, the one that had eight points euchered the one that had nine, and won the game. So Big John took the \$2,000 in gold and stuffed his money belt. He loaded his pack animal, and, with his rifle across the saddle, left without looking back on what he was leaving behind.

He traveled many days and maybe a thousand miles and then he saw a site that he liked, pitched camp, built a cabin, and started over. Fortune smiled as before, for his site was a good one, and today is another important city. As the years rolled by he again became wealthy but remained a bachelor. The great trail ran by the new town, and one autumn he saw a covered wagon with two yoke of bullocks slowly drawing it down the long hill toward the town. A prairie schooner then being a thing of the past, Big John strolled down to the road to await its arrival. As it drew near there loomed into view a wide slatternly looking woman on the front seat, with a background of children who filled the remaining space under the large bow with dirty faces. A man was walking on the far side of the lead bullocks. Finally the cavalcade stopped and the walking man came around in front. It was Little John, again face to face with the partner of his youth, Big John. Big John was first to speak.

"Well, Little John, what in the world are you doing away out in this country?"

Said Little John, "I heered of your prosperity and I jest thought I would mosey out here and find out what other man you had stacked a deck of cards on."

GEOLOGIC REPORT ON HIGH-ALUMINA CLAY DEPOSIT NEAR MOLALLA, OREGON

A large deposit of high-alumina clay occurs approximately three miles southeast of Molalla, Oregon, about thirty miles south of Portland and about thirty miles north of Salem, where a Government plant is now being constructed to test the extraction of alumina from clay. This clay deposit was investigated by the State Department of Geology and Mineral Industries in 1937. Between July 1942 and May 1943, the deposit was investigated jointly by the U.S. Geological Survey and the U.S. Bureau of Mines. In this latter project, 77 holes having a total footage of nearly 8000 feet were drilled and over 30,000,000 dry tons of measured ore containing 25.7 percent of available alumina and 7.7 percent of available iron were indicated.

A preliminary geological report on the area has been prepared by Dr. Robert L. Nichols, field geologist in the High-Alumina Clay Division of the U.S. Geological Survey, and this report together with maps may be examined at the office of the State Department of Geology and Mineral Industries at 702 Woodlark Building, Portland.

* * * * *

OREGON ANTIMONY

Oregon deposits of antimony, a metal in great wartime demand for shrapnel, bearings, and storage batteries, are described in a short report just issued by the State Department of Geology and Mineral Industries. The title is "Antimony in Oregon" and the report was prepared by Norman S. Wagner, field geologist of the Department stationed at Baker. The report describes antimony mines and prospects in the State and also treats briefly of economics and properties of this important war metal.

Prior to the entrance of this country into the war, the United States had depended largely on imports for certain metals to supply our industries. Antimony was one of these metals and had been imported mainly from China where there are large deposits of stibnite, the sulphide of antimony. Because of shipping difficulties, the supply from China was cut off and it was necessary to increase domestic production as much as possible. This increase was attained and United States production, aided by imports from Mexico and South America, was soon able to meet all essential demands.

This report, G.M.I. Short Paper No. 13, is one of a series which the Department has made in the study of Oregon's war mineral deposits. It is available at either the Portland office or the field offices at Baker and Grants Pass.

DEPARTMENT NOTES

Elton Youngberg, formerly general superintendent of the Benton mine in Josephine County at the time of its closing down in 1942 because of war conditions, and more recently mineral specialist with the U.S. Tariff Commission, has succeeded Dr. W.A.G. Bennett as field engineer for the Department at Grants Pass. Dr. Bennett resigned in order to undertake work for the Washington State Division of Mines at Olympia.

* * * * *

John Eliot Allen, Department geologist, has been given a leave of absence to do graduate work at the University of California.

* * * * *

Mr. R. E. Stewart has joined the staff of the Department as paleontologist. Mr. Stewart, formerly geologist and engineer with the Chansler Canfield Midway Oil Co., has for several years specialized in micropaleontology.

STATE DEPARTMENT OF GEOLOGY & MINERAL INDUSTRIES
Head Office: 702 Woodlark Bldg., Portland 5, Oregon

State Governing Board

W. H. Strayer, Chairman	Baker	F. W. Libbey	Director
Niel R. Allen	Grants Pass	John Eliot Allen	Geologist
S. H. Williston	Portland	Esther W. Miller	Ceramic Engineer

State Field Offices

714 E. H Street, Grants Pass	2033 First Street, Baker
Elton A. Youngberg, Field Geologist	Norman S. Wagner, Field Geologist

THE DRY ICE INDUSTRY IN THE PACIFIC NORTHWEST

by

J. C. Stevens*

The production of solid carbon dioxide in the Pacific Northwest dates from the depression period of 1932. In those days it was very difficult to find a market for the dry ice that could be produced; today it is just as difficult to find enough dry ice to satisfy the market.

There are two plants in the Pacific Northwest producing dry ice. One is the Liquid Carbonic Pacific Corporation in Seattle and the other is the Gas-Ice Corporation also of Seattle with a plant at Klickitat, Washington. The former organization produces the carbon dioxide from which dry ice is made by the burning of petroleum fuels. The plant at Klickitat, Washington, utilizes natural carbon dioxide obtained from wells. The combined capacity of both plants is about 25 tons per day.

Carbon dioxide is a colorless non-inflammable gas at normal temperature. Twelve cubic feet at atmospheric pressure weighs about one pound. It exists as a liquid at -76° F and as a solid at -110° F at atmospheric pressure. A cubic foot of dry ice weighs between 90 and 100 pounds depending on the degree of compression. It sublimates directly to gas leaving no trace.

Sources:

Whenever fuel is burned large quantities of carbon dioxide are given off as a product of combustion. It is also given off in the processes of fermentation. Attempts have been made with some measure of success to utilize the smoke from steam generating plants. The difficulty has been the cost of separating the carbon dioxide from other gases with which it is mixed. Probably the greatest single producer of dry ice today is Michigan Alkali, a corporation closely held in the family of John B. Ford, Jr. (Fortune, July 1932). Carbon dioxide is a by-product of the chemical processes carried on by that company mostly by the burning of coke.

Natural carbon dioxide is given off from deep-seated volcanic magmas in their process of cooling. This carbon dioxide is mixed with a large number of other gases. These gaseous mixtures may remain confined under enormous pressures or they may gradually filter upward through the earth to the surface and be discharged to the atmosphere. As these gases rise through the earth's crust they encounter percolating surface waters moving downward, which become heated where percolation is deep. These waters aid the rocks of the earth's crust in absorbing the various gases. It may thus happen that carbon dioxide is the only gas left to reach the surface.

* Stevens & Keen, Consulting Engineers, Portland, Oregon.

In some instances these gases are encountered in wells drilled for oil or fuel gas. Not infrequently the carbon dioxide thus found is under enormous pressure and, as it reaches the surface, the adiabatic expansion cools it down so rapidly that it solidifies in the form of snow. Some such wells in the West give off such enormous quantities of gas at such high pressure that the derricks and surroundings become covered with carbon dioxide snow. A well near Price, Utah, produces carbon dioxide gas at a pressure of about 500 lb. per square inch. This is piped into the dry-ice plant and of course saves much of the mechanical compression that would otherwise be required. However the gas is impure and must be "scrubbed" to remove sulphurous and other gases.

History:

Some businesses get their start in odd ways; the dry-ice industry is an example.

Herbert Samuel Elworthy, a physician in the British army, liked his Scotch and soda. Soda was not always obtainable as it had to come from natural carbonated spring waters and for the most part from Vichy, France.

Sir Herbert decided he could carbonate tap water and thus find a fair substitute. He therefore proceeded to experiment with the idea and finally produced liquid carbon dioxide. The heavy iron containers required, however, were a serious handicap to the enjoyment of his favorite beverage so he continued his experiments and finally succeeded in solidifying the gas. Thus the bulk packaging was reduced to its lowest denominator and Sir Herbert was happy.

He took out a patent on his processes in 1897. However, 25 years elapsed before any further attempt was made to utilize this product, and of course the Elworthy patents had expired and anyone could use them.

In 1923 a company was formed in Long Island City, named Prest Air Devices Co. The company offered solid carbon dioxide for use in a goodly number of novelties. Among them may be mentioned the Prest Air Tire Pump - a device to fill automobile tires with CO₂ gas from a small liquid container carried in the car in the "get out and get under days." This device met defeat when it was discovered that, like Romeo's "stony limits can not hold love out," rubber could not hold carbon dioxide gas in - it filtered through the rubber.

The next was a Prest Air Home Siphon - just what Sir Herbert would have given his eyeteeth for. Another was a device that came to stay - the Prest Air Fire Extinguisher invented by Thomas Benton Slate, an officer in the company. Prest Air Devices Company was officered by a group of inventors who developed many gadgets but no customers and the company was wrecked on the financial rocks.

A successful successor was the Dry Ice Corporation of America who did develop customers. One of the first was Frank C. Shattuck, manager of the Schriff store at 181 Broadway, New York City. The idea of holding ice cream between the moment of purchase and that of consumption appealed to him very much. Accordingly he made a small container for both ice cream and dry ice. One of his first sales however resulted disastrously. A customer's children ate the dry ice and went into convulsions. Whereupon the father filed suit against Schriff's for damages. However he later withdrew it when Shattuck himself and the corporation's representative both ate dry ice in the father's presence to demonstrate its harmlessness.

By 1929 the Dry Ice Corporation of America had 17 plants from New York to Los Angeles. In that year it produced a total of 14,000 tons and the dry-ice industry outgrew its swaddling clothes.

The company has given to the world the name "Dry Ice" - a trade name for a specialized product but now the accepted generic term for solid carbon dioxide. An interesting article on this industry appeared in Fortune, July 1932.

The Klickitat field:

The carbon dioxide gas in the Klickitat field comes from a volcanic magma probably located 10 miles or so below the surface of the earth. As these gases rise through the earth's crust and the zone of permanent water saturation, all other gases are absorbed leaving only pure carbon dioxide to reach the surface. This process has been going on for millions of years and will continue for untold generations to come. Samples taken show a small amount of nitrogen and oxygen but the probabilities are that these are from air mixed with the sample. It is rather difficult to get a sample of the gas entirely devoid of air.

Upon reaching the surface this gas is dissipated over a large area in the vicinity of the town of Klickitat. Owing to certain peculiar characteristics of the earth's crust, the gases appear to have greater concentrations in certain areas, doubtless due to faults or non-conformities between successive lava flows which have been cut by the Klickitat River and its tributaries.

Carbon dioxide gas is a prominent constituent of the natural Klickitat mineral water. It bubbles up through the bed of the river and along the shores and springs and various other places in the area. These Klickitat springs were known to the Indians and used by them extensively as a health resort. The production has been increased by drilling wells, nearly all of which are artesian in nature.

In the beginning of the development, the gas was taken entirely from the mineral water, from which it was separated and then passed into the plant for manufacture into dry ice. Later however it was discovered that wells drilled along the benches of the river canyon would produce dry carbon dioxide free from mineral water. The reason is obvious. This gas is moving horizontally into the river canyon through the broken lavas and non-conformities between the successive lava flows. It is only necessary therefore to penetrate these non-conformities by wells to bring in a dry gas well.

The pressure of the gas is low - 2 to 3 pounds per square inch. The wells do not tap the magma of course; they merely form a less resistant path by which the gas may reach the surface rather than filter up through the ground. After rains the soil is less porous and the pressures in the wells increase.

One means of detecting the localities of gas concentration issuing from the ground is to observe where melting occurs immediately after a snowfall. This gas is at a temperature of about 62° F and as it reaches the surface it melts the snow. Along fault lines therefore and at the exposed non-conformities between lava flows the snow will be melted in large surface patterns that indicate concentrated escape routes for the gas.

Manufacturing process:

No matter what the origin of the carbon dioxide, the process of solidifying it is practically the same at all plants. The gas must be freed from all water vapor and other gases if present by passing it through drying and scrubbing devices. It is then compressed and at the same time is cooled by refrigeration until it forms liquid carbon dioxide at about 0° F under a pressure of 340 lb. per square inch. This liquid is then allowed to expand through a small orifice into a snow press, which is a chamber having pistons operated by a hydraulic press that can produce pressures up to 1200 lb. per square inch. Of the gas so expanded in this chamber about half is converted into a solid in the form of snow; the other half is returned for recirculation through the plant.

The snow is then compressed into cakes by this hydraulic press. When so compressed it weighs nearly 100 lb. per cubic foot and is at a temperature of about 110° below 0° F at atmospheric pressure. The cakes from the Klickitat plant are 10 x 10 x 15 inches and weigh between 80 and 90 pounds. Upon removal from the press they are wrapped in paper cartons and stored temporarily in a heavily insulated box to prevent loss of the gas. Dry ice is transported and sold in cartons. It may be reconverted later into liquid carbon dioxide to fill the containers used by soda fountains and bottling works.

A process has recently been developed whereby liquid carbon dioxide is delivered to customers somewhat along the same line as gasoline would be delivered from trucks. The trucks in this case however are refrigerated in order to keep the pressure down to between 300 and 400 pounds. This process avoids the freight charges on heavy steel containers that would otherwise have to be shipped by the consumer to the factory for refilling. When carbon dioxide is at 70° F it develops a gage pressure of 845 pounds per square inch and reaches a gage pressure of 1000 psi at 82° F. The cost of refrigeration therefore must be balanced against the cost of containers strong enough to withstand such high pressures.

Uses:

The uses of dry ice are manifold. It has not yet been developed as a practicable refrigerant for household use. It is used extensively in transcontinental shipments to prevent water ice from melting so rapidly. Another important use is its value in fruit shipment, not entirely as a refrigerant however but to envelop the fruit in a CO₂ atmosphere and thus prevent decay. For example, cherries shipped from the Pacific to the Atlantic coast will lose from 7 to 10 percent in a transcontinental trip if held with water ice alone. By putting cakes of dry ice in the car an atmosphere of carbon dioxide is created which reduces the loss to less than 1 percent of the shipment.

Dry ice is used also as a refrigerant to send fish, meat, fruits, and other perishable goods through the mails since there is no drip from the packages. It is used to produce rapid freezing of fruit. It seems that perishable foods if frozen very rapidly will hold their natural flavor much better than if they are frozen by the normal mechanical processes.

Another use for dry ice has been developed in the airplane industry. In order to get rivets tight they are first cooled with dry ice and then driven into the holes. The resulting expansion fills the holes solidly and prevents them from working loose.

Since carbon dioxide is non-inflammable it is used to a great extent in fire extinguishers where it is in the liquid form. Filling the heavy steel containers for power plants on land and in ships is frequently done by liquifying dry ice, thus saving shipment of empty containers.

The most general use of dry ice is in the ice cream and dairy industry. Enormous quantities are used in trucks that gather milk and cream. Ice cream is very often retailed with a few pieces of dry ice in the package to hold the ice cream frozen between sale and consumption. Long distance shipments of ice cream depend upon dry ice almost exclusively to keep it frozen during transit.

Production:

The accompanying table shows the production of dry ice in the Northwest and in the United States since 1929. From this tabulation it is apparent that the production in the Pacific Northwest for the 11 years - 1933 through 1943 - has increased 10 times.

Production of solid carbon dioxide (dry ice) in
The United States and in the Pacific Northwest

<u>Year</u>	<u>Pacific Northwest</u>		<u>United States</u>	
	<u>Tons</u>	<u>Tons</u>	<u>Authority</u>	
1929	----	14,000	<u>Fortune, July 1932</u>	
1930	----	35,000	"	" "
1931	----	45,000	"	" "
1932	250	60,000	"	" "
1933	356	----		
1934	546	----		
1935	810	----		
1936	936	----		
1937	1,050	156,600	1940 census	
1938	1,130	----		
1939	1,490	178,400	"	"
1940	1,730	----		
1941	2,560	214,700	War Prod. Board	
1942	2,940	252,800	"	" "
1943	3,550	270,000	"	" "
1944 (partly estimated)	4,030	300,000		

Future demands:

It is of course impossible to predict the future of the dry-ice industry. New uses for it are being found every day. One thing appears certain. The industry is here to stay with an ever-widening field.

In the early days the Dry Ice Corporation of America, one of the earliest producing agencies, set up the following potentialities as an annual target:

Carbonated beverages	44,000 tons
Transportation of fruits and vegetables	37,500
Ice cream refrigeration	150,000
Frozen foods	1,500,000
Express and truck for unfrozen meats	90,000
Refrigeration of carload shipments of perishable food stuffs	1,800,000
Total annual demand	3,621,500 tons

This is only 12 times the 1944 production and is not at all impossible of realization.

Prices:

The sale price of dry ice has varied from 5 cents per pound in the early days of the industry to 1.5 cents or possibly even lower in the competitive market of Michigan Alkali.

Average prices are disclosed in the following tabulation:

<u>Authority</u>	<u>Period</u>	<u>Production tons</u>	<u>Revenue</u>	<u>Average revenue per ton</u>
Gas-Ice Corp. ^{1/} _{2/}	1932-1944	14,650	\$ 864,602	\$ 59.20
U. S. Census ^{1/} _{2/}	1937	156,600	4,618,937	29.50
" "	1939	178,400	5,532,315	30.90

^{1/} Based on actual sales and actual revenue.

^{2/} Production may substantially exceed actual sales and thus reduce average revenue. The revenues given are identified as "value" in the 1940 census report and may not represent actual sales.

Ashland, Oregon, plant:

The lithia water springs at Ashland are a source of natural carbon dioxide. The Gas-Ice Corporation of Seattle and Klickitat owns leases and land surrounding these springs and is now engaged in the construction of a second plant for the manufacture of dry ice. This plant will have an initial capacity of 5 tons per day, which will be increased to 10 tons per day as soon as the exigencies of the war will permit. It is also contemplated that both the Klickitat and the Ashland plants will in a few years be increased to 20 tons daily capacity each.

MERCURY IN SEPTEMBER 1944

According to the U.S. Bureau of Mines monthly mercury report released November 3, 1944, production and consumption of mercury in September showed no change from the 2500 and 3900 flasks, respectively, reported for August and, as a consequence, stocks again decreased notably. The Abbott, New Idria, New Almaden, Mt. Jackson, and Reed mines in California, the Cordero in Nevada, and the Bonanza in Oregon produced 84 percent of the September total. Eleven other mines that produced more than 15 flasks each are as follows: Ord and Pine Mountain in Arizona; Helen, Mirabel, Knoxville, Guadalupe, Culver-Baer, and Altoona in California; Red Rock in Nevada; Horse Heaven in Oregon and Waldron in Texas.

Salient statistics on mercury in the United States in 1939-43 and in January-September 1944, in flasks of 76 pounds each

Period	Production	Consumption	Stocks at end of period		Price per flask at New York
			Consumers and dealers 1/	Producers 2/	
Average Monthly					
1939 . . .	1,553	3/ 1,742	12,600	376	\$ 103.94
1940 . . .	3,148	2,233	14,100	607	176.87
1941 . . .	3,743	3,733	12,400	439	185.02
1942 . . .	4,237	4,142	10,700	1,377	196.35
1943 . . .	4/ 4,327	4,542	13,200	3,457	195.21
Monthly					
1944:					
January	4,400	3,400	11,300	5,459	151.60
February	3,800	3,700	9,400	5,450	130.00
March	3,800	3,600	9,900	5,011	130.00
April	3,700	3,200	9,700	5,604	128.20
May	3,400	3,100	8,900	6,171	115.54
June	3,000	3,400	9,000	5,757	101.69
July	2,700	3,000	9,300	4,025	100.56
August	2,500	3,900	9,100	2,252	104.04
September	2,500	3,900	8,400	1,936	104.28

1/ Largely excludes redistilled metal. 2/ Held by reporting companies. 3/ Apparent consumption. 4/ Based on final figures.

CH-82 -

For sale:

Nearly new 25-ton Herreshoff quicksilver furnace; used only 6 months; now set up about 38 miles north of Medford. Asking price \$9300. Communicate with Mr. L. Nabut, Security Bldg., Portland, Oregon. Phone ATwater 9211.

STATE DEPARTMENT OF GEOLOGY & MINERAL INDUSTRIES
Head Office: 702 Woodlark Bldg., Portland 5, Oregon

State Governing Board

W. H. Strayer, Chairman	Baker	F. W. Libbey	Director
Niel R. Allen	Grants Pass	John Eliot Allen	Geologist
S. H. Williston	Portland	Esther W. Miller	Ceramic Engineer

State Field Offices

714 E. H Street, Grants Pass	2033 First Street, Baker
Elton A. Youngberg, Field Geologist	Norman S. Wagner, Field Geologist

AUGER HOLE PROSPECTING

by

Ralph S. Mason *

The following description of drilling methods used by the Oregon Department of Geology and Mineral Industries in exploring ferruginous bauxite deposits in northern Washington County, Oregon, may be of interest to anyone who plans to do similar exploration.

During the fall of 1944, 22 holes were drilled having a total depth of 605 feet, an average of approximately 28 feet per hole. The deepest hole drilled was 45 feet. The area explored extended along a ridge approximately 2 miles in length. This ridge has fairly steep slopes on both sides although the ridge itself is for the most part flat-topped. The entire area was logged off 10 or 15 years ago, and the ground is now covered with brush and scrub growth as much as 15 or 20 feet high.

The ore occurs in a bedded deposit or deposits having a dip corresponding roughly to the surface of the top of the ridge and lying from 5 to 30 feet beneath the surface. Overburden consists for the most part of light-colored silts and clays which are easily penetrated with an auger. The ore is characteristically reddish in color and usually has a gritty texture, although both color and texture vary widely.

The first part of the drilling project consisted of putting down a few closely spaced holes in order to determine the attitude of the ore body. Once this was determined it was possible to locate additional holes at 1500-foot intervals along the ridge so that they would strike the ore most effectively. The project was planned to indicate extent of the deposit, not to prove exact tonnage.

In general all of the holes drilled required the use of either the 3-inch or 2-inch "Iwan" soil auger, the 3-inch auger being used to start all holes while the 2-inch was used when the ground became too hard to penetrate with the 3-inch drill, and had to be loosened with a 2-inch coal auger bit. Holes deeper than 30 feet were generally drilled with the 2-inch auger in order to reduce friction along the walls of the hole and also because of its lighter weight.

The 3-inch drill used had a 3/4-inch pipe-thread, and the drill pipe consisted of standard 3/4-inch galvanized iron pipe. The 2-inch auger had 1/2-inch threads, and a 1/2 by 2-inch nipple and 1/2 by 3/4-inch bushing were used to adapt it to the 3/4-inch pipe. The coal auger, similar to those used in coal mines, was a regular hand-twist drill with a 3/4-inch pipe coupling welded to the shank.

* Mining Engineer, Oregon Department of Geology and Mineral Industries.

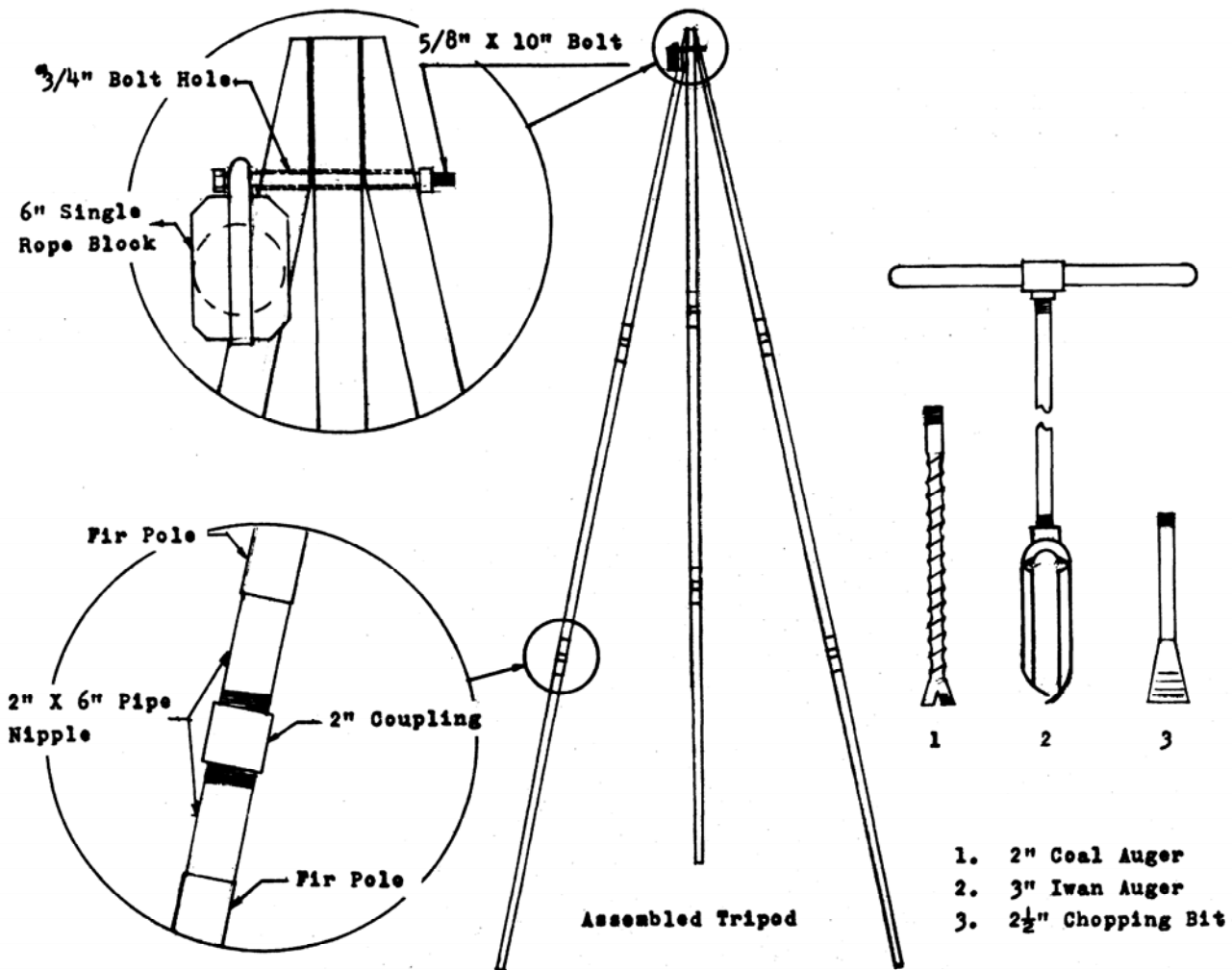

Holes that were drilled deeper than 15 or 20 feet required the aid of a tripod to help pull the drill pipe and pod out of the hole. The tripod used on this project was the result of considerable experimentation on other similar projects of the Department, and was made up of portable joints or sections of fir poles $2\frac{1}{2}$ inches in diameter and 9 feet long.

Each leg of the tripod consisted of three sections joined together by turning down the ends of the poles and forcing 2-inch pipe nipples, 6 inches long, to a flush joint, and coupling the sections together with regular pipe couplings. Details of construction of the tripod are shown in the accompanying diagram. In order to conserve weight without making the tripod unduly limber, the middle section of each leg was made from a slightly thicker pole than the top and bottom sections which tapered toward the ends.

A $\frac{3}{4}$ -inch hole was drilled about 6 inches from the upper end of all three poles and a $\frac{5}{8}$ by 10-inch bolt was used to assemble the tripod. The hole in the "middle" leg was drilled at right angles to the length of the pole, and the other two holes were drilled at a slight angle to permit proper spreading of the legs. A 6-inch single block with a $\frac{5}{8}$ -inch rope 50 feet long was attached to the top of the tripod by means of the bolt connecting the legs.

Best results were obtained when the block at the apex of the tripod was attached as shown in the drawing. This arrangement permitted passage of the pipe above the block without interference from the closely spaced poles when holes were drilled deeper than 25 feet. The rope used in the block had a loop braided in one end large enough to slip over the drill handle. This loop was wound with wire to protect it from wear and to help keep it open for free passage of the pipe. The other end of this rope was equipped with a harness snap which was hooked to a large screw eye screwed into a tripod leg about 5 feet from the ground. The total weight of the assembled tripod, including rope and block, was approximately 130 pounds. Cost of the tripod hardware, rope, and block amounted to about \$17.00. The fir poles were cut and fitted in the field.

Total cost of drilling equipment, which included one 3-inch auger, one 2-inch auger (each drill came supplied with a handle and 3 feet of 3/4-inch pipe), two pipe wrenches, and 39 feet of 3/4-inch pipe with couplings, amounted to approximately \$17.00. Since the drill rig would be used for various exploration projects in the future, and in areas that might be some distance from repair facilities, all of the pieces comprising the tripod hardware and drill pipe were either standard pipe fittings or hardware supplies obtainable at any plumbing shop or hardware store. The soil augers are likewise commonly stocked by hardware stores, as are also the pipe wrenches, rope, and rope block. The only item which might not be generally available would be the fir poles used in the tripod, but rough straight-grained lumber could possibly be substituted.

The drill crew consisted of a driller and sampler who at intervals usually switched duties. The actual drilling operation consisted of, first, preparation of the drill site. This required removal of any brush or logs, and the scraping of debris from the area surrounding the collar of the hole. When it was known beforehand that the hole would be deeper than 15 or 20 feet, the tripod was immediately set up and put in use after the first 9 feet had been drilled.

Usually the driller started the new hole while the sampler transferred and assembled the tripod. This effected a considerable saving of time, since normally no samples were taken for the first few feet and the drilling could be done easily by one man.

Assembling the three legs of the tripod (the sections of each leg were not unscrewed for short moves between holes) required less than 5 minutes. The legs were placed in position and bolted together with the block attached at one end of the bolt. The lower ends of the two "outside" legs were placed about 8 feet apart and about 6 feet from the hole collar. To erect the tripod, one man lifted the upper ends of the three legs where they were bolted together and the second man pushed in on the middle leg. Once raised to full height the tripod was moved slightly to bring the block directly over the hole. On flat, even ground, the three legs were kept about 8 feet apart at the corners of an equilateral triangle. This spacing gave maximum height and structural strength.

As the hole was deepened, additional lengths of pipe 3 feet long were added to the drill. In order to reduce the number of couplings in the drill pipe, 6-foot lengths were substituted for the 3-foot pieces as the drilling progressed. The use of 9-foot pipe lengths would have proved advantageous, as a much smoother and straighter string of pipe would have resulted.

When the hole reached a depth of 9 feet, the rope and pulley were used to haul the drill pipe from the hole and to keep it suspended while the pod was unloaded. When the drill was ready to be returned to the bottom of the hole, the driller grasped the rope, using a gunny sack for protection against rope burns, and let the drill down into the hole as rapidly as possible. As most of the material drilled was more or less damp, it was somewhat difficult to remove from the pod. A corn knife proved to be a handy tool for this purpose. When holes deeper than 25 feet were drilled, it was necessary to lift

the string of pipe up beyond the block. First the pipe was pulled up with the rope until the loop entered the block, and then the rope was held by one man while the other lifted the string of pipe out of the hole. An improvement of this practice - which was exceedingly strenuous when holes 30 or 45 feet deep were drilled - would be to use a double block with a second rope equipped with a hook at one end. The hook would fit into a tee inserted in the string of pipe at the point where the pipe emerges from the ground when the handles have been raised up to the block by the first rope. The second rope would then be used to elevate the remaining pipe enough to clear the pod. This system has not yet been tried in the field but it probably would be a time and labor-saving device.

While the 3-inch and 2-inch Iwan-type soil augers penetrated most of the semi-solid soils and altered rocks, there were some hard ribs or strata encountered which could not be drilled with these augers. When such material was struck, the first step was to switch from either the 2-inch or 3-inch auger to the 2-inch coal auger mentioned above. This coal auger was usually able to penetrate consolidated material provided the material was not too hard. The usual practice was to twist this auger down as far as possible with frequent unwindings. The auger was then removed without attempting to bring any loosened material out, and the soil auger was put back on the string of pipe. This procedure had to be repeated many times in hard "olitic material, but with practice the change from one drill to the other was made in 10 seconds or less.

Care was exercised when using the coal auger in material being sampled as it mixed up several inches of material at the bottom of the hole, and, if there were a sudden change in the composition of the bed, some "salting" would occur. For material that was too hard to be drilled with the coal auger, a light forged chisel bit was used occasionally. This bit was alternately lifted and dropped while being slowly rotated and was generally able to break up fairly solid material.

In wet, plastic clay considerable difficulty was experienced when the soil auger was pulled out owing to the suction created. The best practice was to avoid overloading the auger, and to rotate the drill slowly while lifting it. For several reasons it is not good practice to fill the pod of the auger too full. First, when the pod is tightly packed with material the sides of the pod might be pushed outwards slightly and might bind along the walls of the hole when being removed; second, material might be forced out of the top of the pod and might either be lost on the way out of the hole or be smeared along the walls, thus possibly contaminating subsequent samples; third, tightly packed material was often difficult to remove from the auger; and fourth, careful measurements of the advance per revolution of the auger revealed that an excessive amount of effort had to be expended to advance the drill once the pod was full. In general, the pod was filled and cleaned three or four times in making 1 foot of hole.

Sampling of the material removed from the drill hole required careful attention. First, the exact depth of the pod was determined for each sample taken. This was done by measuring the length of pipe, starting at the tip of the pod and marking the distance on the pipe with keel.

The thickness of the samples varied somewhat. In some cases where the material being sampled showed little change in texture, color, and moisture content, samples representing 3 or 4 feet in thickness were taken. Samples of this thickness were generally restricted to zones which were not thought to contain ore and were taken merely for checking. In the ore zone proper, most samples were taken every 2 feet and in some cases every foot. Whenever any distinct change occurred in the appearance of the ore, a new sample was started regardless of the thickness of the preceding sample. The sampling interval was purposely restricted to narrow limits in order to delimit accurately the ore body.

When the filled drill pod was brought to the surface, the material was immediately removed and placed in a glass jar with a moisture-tight seal.

The most satisfactory method of labeling the jars was to use a list of field numbers which had been previously typed in columns on a sheet of paper. Numbers were cut from the sheet and attached to the top of the jar by means of cellulose tape. This system saves much writing in the field, and the jars can be labeled in advance or during some free time on the job.

A complete log of the hole was kept on mimeographed 8½ by 11-inch sheets prepared for this purpose. These forms provided space for the location of the hole, elevation of the collar, depth to the top of the bed, depth of the hole, elevation of the water table, and the material in which the hole was bottomed. Spaces were also provided for the sample interval, the depth at which the sample was taken, the sample number, and a description of the material sampled. As an adequate description of the material sampled was helpful in determining the nature of the ore body and the overburden, and as this required a considerable amount of writing, a sample key listing the common colors, textures, and compositions was drawn up. Each of the terms listed in the key was given either a letter or a number, and these letters and numbers were then used on the log instead of writing out the entire description in longhand. This saved a great deal of time, and permitted a complete description of the material in the small space allotted.

The rate of drilling varied widely from hole to hole and was largely governed by the nature of the material drilled. In addition the rate of drilling varies inversely with the depth of the hole. The following figures summarize the cost of drilling and sampling on the project. The first set of figures includes one hour travel time while the second includes only actual time spent on the ground.

<u>Interval</u>	<u>Drilling & sampling time, hr.</u>	<u>Distance drilled, ft.</u>	<u>Advance per hr., ft.</u>	<u>Feet per man hr.</u>	<u>Total cost drilling & sampling, ft.</u>
All holes, 8 hrs. (elapsed time)	155.00	605.5	3.906	2.604	\$ 0.512
All holes, 7 hrs. (actual drilling time)	135.62	605.5	4.464	2.976	\$ 0.448

In addition to the above costs a slight depreciation charge should be made for equipment worn out on the job. Little apparent wear occurred on the 3-inch auger after drilling more than 500 feet of hole, but the 2-inch auger showed considerable wear after a much shorter footage and had to be replaced when it broke into two pieces while drilling. This increased wear on the 2-inch auger was largely due to the fact that it was used only in either hard ground which could not be drilled by the 3-inch auger alone or in very deep holes where the weight of the string of pipe was considerable. Breakage of pipe and pipe-fittings was negligible, and wear and tear on wrenches, rope, and tripod hardware was also inconsequential.

OREGON MINING ASSOCIATION

The annual meeting of the Oregon Mining Association was held in Portland on December 1, and the following officers were elected: President, S. H. Williston; Vice-president and Secretary, Irving Rand; Directors, Worthen Bradley, D. Ford McCormick, and F. Whalley Watson. The office of the association is at 1105 Public Service Bldg., Portland, Oregon.

MINING LAWS IN O & C BILL

Mining laws were made applicable to the Oregon-California revested grant lands under an amendment added by Representative White (D-Idaho) to the O & C authority bill.

The public lands committee approved White's amendment to the bill adding a mining provision similar to that contained in the Taylor Grazing act. It reads:

"Nothing herein contained shall restrict prospecting, locating, development of mining, entering, leasing, or patenting mining reservations under laws applicable thereto."

The bill itself would transfer the administration of revested forest lands, now handled by the forest service, to the O & C administration. It has been placed on the House calendar with favorable committee recommendation.

Grants Pass Courier

Grants Pass, Oregon, Dec. 5, 1944.

ANNUAL MINING INSTITUTE AT THE UNIVERSITY OF WASHINGTON, SEATTLE

The 18th Annual Mining Institute of the College of Mines, University of Washington, will be held on Wednesday, January 24, 1945. The program beginning in Mines Laboratory at 10:00 a.m. will include among others the following speakers: John J. Curzon, manager of Howe Sound Company's Holden mine, who will outline and illustrate the "Changing Mining Methods at Holden," and Glenville A. Collins, president of North American Gold Fields, Ltd., who will describe and show motion pictures of "Drag-Line Gold Dredging in the Cariboo, B.C."; views of similar operations in California and of travel in the North will be included.

The luncheon will be in charge of the West Coast Mineral Association. In the afternoon a 225-ton press and other new equipment of the College of Mines and the Northwest Experiment Station will be demonstrated, along with exhibits of new machinery from the manufacturers. Bureau of Mines sound films on "Magnesium - Metal from the Sea" and "Airplanes - Their Metals, Fuels, and Lubricants" will be shown. At 6:00 p.m. a joint dinner will be held at the Faculty Club with the North Pacific Section of A.I.M.E. At 8:00 p.m. Russell Spry, ore-dressing engineer of Vancouver, B.C., will give an illustrated address on "Mill Planning for New Properties."

DECLARATION OF POLICY

of

Northwest Mining Association

Golden Anniversary Meeting

December 1944

The Northwest Mining Association, in its 50th Annual Meeting, looks back over half a century of unparalleled progress under the American system of competitive free enterprise, and looks forward to another fifty years which must see the restoration and improvement of this time honored system after the present emergency.

The Mining Industry has been called upon to supply in unprecedented amounts the basic minerals vital to Victory. We pledge our continued cooperation to the prosecution of the war, recognizing that until the day of ultimate Victory few steps can be taken toward a return to normal conditions.

Free Enterprise

Free enterprise, by whatever name it may be called, is the basis of the American way of life. It has brought to America the world's maximum industrial production and highest standard of living.

Free enterprise requires the highest degree of personal freedom attainable under just laws impartially enforced - freedom to save, invest and venture as we wish - absence of arbitrary controls by government - preservation of property rights under a system of government by law and not by men.

Trade Policy

We emphatically reject the viewpoint that our nation has become a have-not in minerals. Our known and indicated ore reserves are substantially as great as at any previous time and improved operating efficiency has compensated for any decline in grade. Nevertheless, we do not resist a moderate increase in mineral imports commensurate with the recent expansion in national industrial capacity, provided that foreign trade policies do not discriminate against domestic mining. We insist that the stability of domestic economy is a fundamental necessity, and that the government should stockpile any mineral imports in excess of the amounts our national economy can absorb without dislocation.

Premium-Quota Plan

The premium-quota plan was adopted as a wartime measure to obtain necessary production under ceiling prices. However, costs have risen under the premium system to an extent that would jeopardize normal production if premiums were removed and present price ceilings continued. Therefore, we urge retention of the premium-quota system until control of prices is abandoned and until operators who have made investments for war production have had a chance to recover these investments.

Tax Reforms

We favor drastic alteration of Federal Tax laws in order to promote development of new mines, and in order to permit operation of existing mines at good rates of production, thus insuring a healthy mining industry and full employment of labor.

We favor a change in the Federal Income Tax law to permit taxpayers to make reasonable deductions from net income for money expended in grubstakes or primary investments in the development of natural resources.

Venture Capital

We recommend that the Securities & Exchange Commission modify its restrictive rules and regulations so that more venture capital may be made available for all business purposes.

Mineral Land Policies

We support the principle of discovery and location as embodied in the Federal Mining Act, and in the administration of this act we urge that discovery be presumed wherever the claim owner performs in good faith the required location and assessment work, and where his possession of the claim is primarily for mining purposes. We oppose any attempt to bring about the Federal recording of mining claims, and favor the continuation of the present system of recording under State laws.

We oppose the adoption or expansion of a leasing system for mineral resources on public lands, on the ground that it restricts and discourages mineral development.

Indian Reservations

We condemn the creation of Indian Reservations except by specific act of Congress, after full congressional hearing in which all interested parties are represented. We advocate repeal of the Wheeler-Howard Act conferring such authority on the Secretary of the Interior, and reconsideration by Congress of all Indian Reservations created in Alaska under that authority.

Re-opening of Gold Mines

We recommend that W.P.B. Order L-208, shutting down gold mines, be rescinded immediately, and that

United States gold producers be permitted to sell newly mined gold in any world market.

Monetary Policy

We favor a currency with a metallic base, using gold and silver. We endorse the continued purchase and coinage of domestic gold and silver, as provided by law, and urge the repeal of the prohibitions on free circulation of gold.

Employee Relationships

We support all efforts to be made by either labor or management that are designed to improve employer-employee relationships. We believe that those relationships can be improved by a limitation of three months on retroactive pay orders imposed by any federal tribunal.

MERCURY IN OCTOBER 1944

According to the U.S. Bureau of Mines monthly mercury report released December 5, 1944, consumption of mercury in October 1944 was again substantially above domestic production, making the third successive month in which the disparity has been noteworthy. As a result, industry stocks were 41 percent below those held January 31, when they were at their highest levels since the Bureau of Mines monthly surveys began in September 1939, and for an indefinite period before that. Stocks at the end of October were the smallest reported in the period covered by the monthly reports. The metal on hand was sufficient for about two and one-half months' needs at the increased rate of consumption in August-October, but supplies were not evenly distributed. The conditions outlined were accompanied, as was to be expected, by a further stiffening of prices during October and by a strong price at the month-end. In order to ease the situation, the War Production Board announced December 1 that it would make releases from the Government stockpile for essential war uses.

Salient statistics on mercury in the United States in 1939-43 and in January-October 1944, in flasks of 76 pounds each.

Period	Production	Consumption	Stocks at end of period		Price per flask at New York
			Consumers and dealers 1/	Producers 2/	
Average Monthly					
1939. . . .	1,553	2/ 1,742	12,600	376	\$ 103.94
1940. . . .	3,148	2,233	14,100	607	176.87
1941. . . .	3,743	3,733	12,400	439	185.02
1942. . . .	4,237	4,142	10,700	1,377	196.35
1943. . . .	4/ 4,327	4,542	13,200	3,457	195.21
Monthly					
1944:					
January .	4,400	3,400	11,300	5,459	151.60
February.	3,800	3,700	9,400	5,450	130.00
March . .	3,800	3,600	9,900	5,011	130.00
April . .	3,700	3,200	9,700	5,604	128.20
May . . .	3,400	3,100	8,900	6,171	115.54
June . . .	3,000	3,400	9,000	5,757	101.69
July . . .	2,700	3,000	9,300	4,025	100.56
August. .	2,500	3,900	9,100	2,252	104.04
September	2,500	3,900	8,400	1,936	104.28
October .	2,700	3,900	7,400	2,550	109.20

1/Largely excludes redistilled metal. 2/Held by reporting companies. 3/Apparent consumption. 4/Based on final figures.

- Activated carbon from Texas lignite (VI:7;51-52)
Alumina, Northwest source of vital (VI:10;65-67)
Aluminum (VI:4;23)
 Dust treatment for silicosis (VI:9;63-64)
Annual Mining Institute at the University of Washington, Seattle (VI:12;82)
Another Tall Tale of a Sourdough (VI:3;20)
Antimony (VI:4;23)
 Oregon (VI:10;70)
Auger hole prospecting (VI:12;77-81)
- Bismuth (VI:3;15-20)
Blast hole diamond drilling (VI:5;36)
- Carbon, activated, from Texas lignite (VI:7;51-52)
Chrome
 Chemicals discussed (VI:8;57-58)
 Mining activity (VI:6;43)
Chromite (VI:4;22)
Clearing House (VI:1;5) (VI:2;14) (VI:11;76)
Coal
 Coming era (VI:4;25-28)
 Shortage (VI:6;44)
Coming coal era (VI:4;25-28)
Copper (VI:4;23)
Critical materials (VI:4;28)
Cyclone Gap property (VI:6;43)
- Declaration of policy of Northwest Mining Association (VI:12;82)
Department notes (VI:10;70)
Diamonds (VI:1;1-5)
Doe Yak (VI:8;58)
Domestic mineral reserves (VI:4;21-25)
Don't you believe it! (VI:4;21-25)
Dry ice industry in the Pacific Northwest, The (VI:11;71-76)
- Fluorspar (VI:6;37-43)
- Geologic report on high-alumina clay deposit near Molalla, Oregon (VI:10;70)
Glaze, What's in a? (VI:2;7-12)
Gold, Bearing on ownership of our "useless" stocks at Fort Knox (VI:9;62-63)
Grant County, Oregon, mining news from (VI:7;52)
Grey Eagle chrome mill (VI:6;43)
- Harrison commissioned in Navy (VI:5;36)
High-alumina clay deposit near Molalla, Oregon, geologic report on (VI:10;70)
- Illinois chrome mine (VI:6;43)
In appreciation (VI:2;12-14)
Iron (VI:4;23)
- Lead (VI:4;23)
- Magnesium (VI:4;23)
Manganese (VI:4;22)
Mercury (VI:4;22)
 Production in the United States in 1943 (VI:1;6) (VI:6;44)
 In July 1944 (VI:9;64)
 In May 1944 (VI:7;46)
 In October 1944 (VI:12;84)
 In September 1944 (VI:11;76)

Microchemistry in research and industry (VI:5;29-36)

Minerals needed (VI:10;68)

Mining Association, Oregon (VI:12;81)

Mining news from Grant County, Oregon (VI:7;52)

Molybdenum (VI:4;22)

Nickel (VI:4;22)

Nixon, Earl K., joins Freeport Sulphur Company (VI:4;28)

Northwest Mining Association, declaration of policy (VI:12;82)

Northwest Source of Alumina Vital (VI:10;65-67)

Oregon antimony (VI:10;70)

Oregon mineral production (VI:10;67)

O and C Lands

Bill, Mining laws in (VI:12;82)

Mineral discovery hamstrung in western Oregon (VI:8;53-54)

Mineral leasing bill (VI:7;48-51)

Mineral rights in revested Oregon lands (VI:7;45-46)

S. 1982 (VI:8;54-55)

Pioneers, The (VI:10;69)

Quicksilver production (VI:10;68)

Shortages (VI:8;55-56)

Silicosis, aluminum dust treatment for (VI:9;63-64)

Sourdough chrome mine (VI:6;43)

Strategic notes (VI:8;55-57)

Synthetic rubber (VI:8;56-57)

Tin (VI:4;21)

Tungsten (VI:4;22)

"Useless" gold stocks at Fort Knox, Bearing on ownership of our (VI:9;62-63)

Vanadium (VI:4;22)

Western States Mining Conference (VI:9;59-62)

What's in a glaze? (VI:2;7-12)

Zinc (VI:4;23)